

**GPS Module
USER MANUAL**

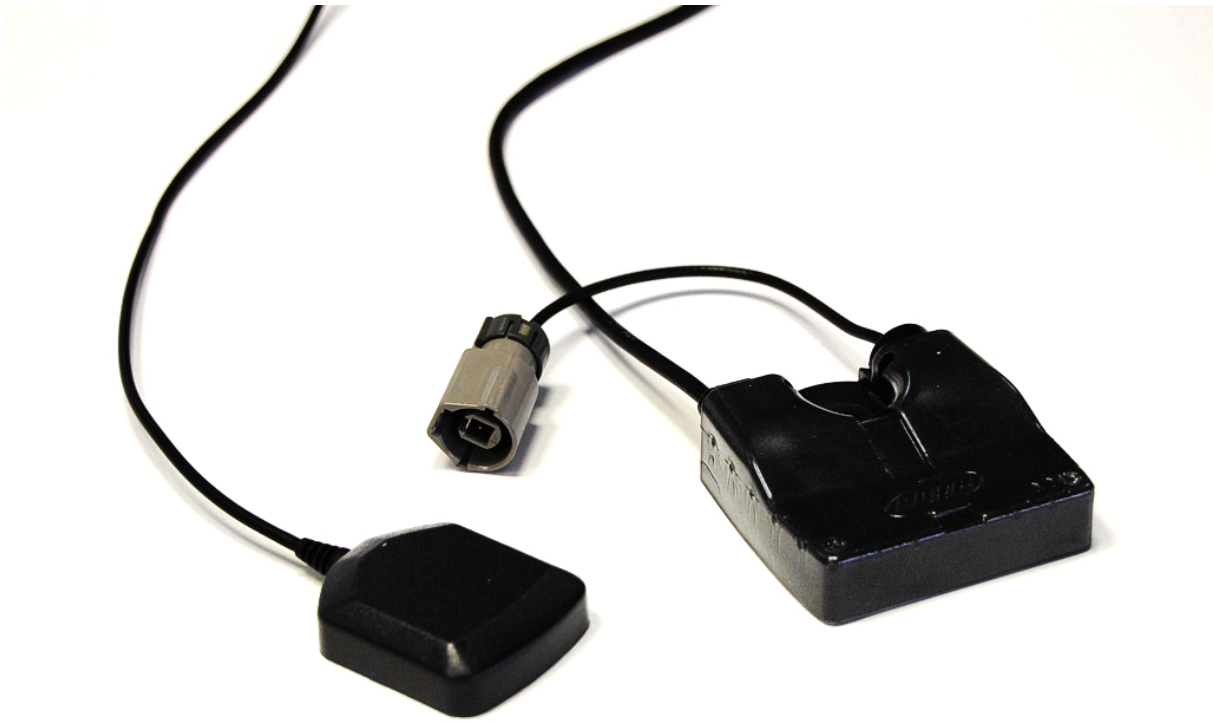

Racing Data Power

GPS Module for **MyChron4 - MXL - EVO3** further expands the already great potentialities of highly innovative and flexible instruments.

We suggest to periodically check on www.aim-sportline.com if AIM published new releases of software and/or firmware for **GPS Module** or for the loggers it can be connected to.

This user manual is to be considered as an integration of the single loggers user ones so, please refer always to them for any information concerning subjects not expressly developed in this manual.

INDEX

1 – GPS Module and MXL	3
1.1 – Connection and Power	3
1.2 – Connection with additional peripherals.....	4
1.3 – Installation on the vehicle	5
1.4 – Configuration Wizard.....	6
1.5 – GPS Laptimer	6
1.5.1 – Preliminary operation.....	6
1.5.2 – How to set GPS beacons.....	7
1.5.3 – Additional functions.....	8
1.6 – Data Visualisation	8
1.7 – Data download.....	8
2 – GPS Module and EVO3	9
2.1 – Connections and Power	9
2.2 – Installation on the vehicle	9
2.3 – Configuration Wizard.....	9
2.4 – Data download.....	9
3 – GPS Module and MyChron4	10
3.1 – Connection and power	10
3.1.1 – Connection with internal power	10
3.1.2 – Connection with external power (recommended).....	11
3.1.3 – Connection on MyChron4 eBox with AIM Data Hub and external power.....	12
3.2 – Installation on the vehicle	13
3.3 – Configuration Wizard.....	13
3.4 – The GPS Lap timer	14
3.4.1 – Preliminary operations.....	14
3.4.2 – Setting GPS Laptimer.....	15
3.4.3 – Additional features and equivalent circuits management.....	16
3.4.4 – Troubleshooting.....	18
3.5 – MyChron4: Data visualisation.....	19
3.5.1 – Data visualisation while recording	19
3.5.2 – Data visualization during data recall.....	20
3.6 – MyChron4 Data key for data download.....	20
4 – GPS Module and MyChron4 660	21
4.1 – How to connect GPS Module	21
4.1.1 – Connection with internal power.	21
4.1.2 – Connection with external power (recommended).....	22
4.2 – How to install GPS Module.....	23
4.3 – Configuration Wizard.....	23
4.4 – MyChron4 660 Data visualization	23
4.5 – MyChron4 660 Data key for data download.....	25
4.6 – GPS Module with QMAN	25
5 – GPS Manager software	26
5.1 – Typical use of GPS Manager.....	29
6 – GPS Module data analysis	30
6.1 – Settings GPS channels graphic view	32
6.1.1 – Colour channel list.....	32
6.1.2 – Bands values	32
6.2 – Race Studio Analysis software – Other functions.....	36
7 – Keep in touch!	40
Appendix – Part numbers	41

1 – GPS Module and MXL

1.1 – Connection and Power

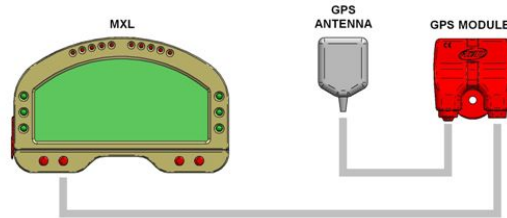

The figure above shows a CAN network made of **MXL Pista** and **GPS Module**. To connect **MXL Pista** to **GPS Module** use the 5 pins connector mounted on the logger back side as shown below.



To connect **MXL Pro** connect **GPS Module** to the CAN cable labelled EXP (expansion) of the logger wiring.

1.2 – Connection with additional peripherals

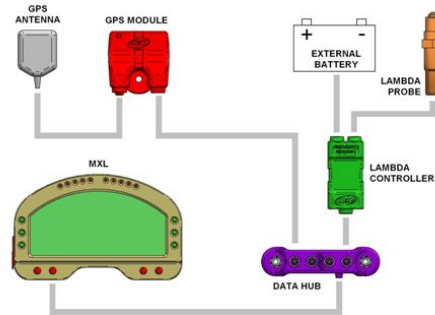

The figure above shows a CAN network of **LCU-ONE** and **GPS Module**. Peripherals can be connected to **Data Hub** using one of the 4 CAN inputs. The CAN network can be further increased using the same logic.

To connect **MXL Pista** to **GPS Module** use the 5 pins connector mounted on the logger back side as shown below.



To connect **MXL Pro** connect **GPS Module** to the CAN cable labelled EXP (expansion) of the logger wiring.

1.3 – Installation on the vehicle

For a proper working of **GPS Module**, please pay attention while installing it on the vehicle.

Install **GPS Module** far from heat sources and let the antenna cable pass as far as possible from electromagnetic sources like coil or alternator.

Please use the proper hole to fix **GPS Module** to a bracket steady on the chassis.

In case of car installations, please place the antenna on the roof of the car so that the magnet on the bottom of the antenna can fix strongly to the metal plate.

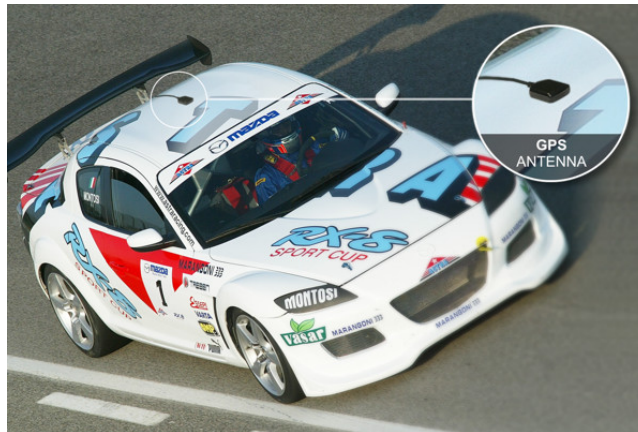

In case of bike installations, please place the antenna on the tail of the bike, where the surface is flat and looking upwards.



Install **GPS Module** near to the biker seat so that CAN cable (less sensitive to electromagnetic radiations) and not GPS antenna cable, passes near to the engine.

1.4 – Configuration Wizard

No system configuration is needed. The systems self-configures at start up.
It is suggested to switch on the system a few minutes before entering the track.

1.5 – GPS Laptimer

GPS Module is now available with a new and very useful feature: lap timing.
It allows to show and record lap/split times without installing any beacon receiver nor transmitters. It is only sufficient a **GPS Module** with firmware version 35.13 or later connected to an **MXL** with firmware version 14.86.22 or later.

The first operation to be done is GPS beacons setting for the complete lap and for the splits. This allows the module to capture lap/split times.

WARNING: this operation is to be performed the first time and once only for each track. Next time the track is automatically recognized by the logger.

1.5.1 – Preliminary operation

GPS Lap timer can detect both lap and split times but, being an external expansion that works as a slave device, its detection mode with or without splits depends on the configuration of its master logger, in this case **MXL**. This means splits have to be set via software in “Lap” box of **Race Studio 2** “System configuration” window (accepted values are between 1 and 6). **MXL** visualization mode is to be set as well as and then configuration has to be transmitted to the logger. Here below is shown how to set these parameters.

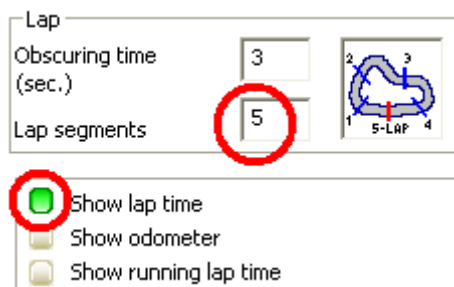

Please refer to **Race Studio Configuration** user manual for further information about the system configuration.

1.5.2 – How to set GPS beacons

Here follow the steps to set start/finish line and splits position of **GPS Module**:

- Ensure **GPS Module** is correctly connected to **MXL**
- Press “MENU” button on **MXL** keyboard.
- The system shows a menu with backlight and GPS options
- Select “Set GPS beacon” using “>>/<<” buttons
- Press “OK” button



MXL asks to set start/finish line

Reach the point to be considered as start/finish line and press “OK” button
Start/finish line position is saved.



Once start/finish line is set, if the system is configured to capture splits, the page shown below appears; reach the point of the track to be considered as split and press “OK” button.



Once the configuration is over, the system shows start page and can record times. “TRK”, circled in the figure below, confirms that the track has been recognised lap and split times can be recorded.



To cancel the proceeding switch **MXL** off and then on again.

Warning:

- in case of low signal the system could ask again for beacon settings.
- do not set lap or split markers under bridges or near to obstacles.

1.5.3 – Additional functions

GPS Module can record up to 50 track configurations with up to 5 splits for each track. Once the number of 50 tracks reached it is necessary to download data on a PC to manage more tracks. Once saved, the circuit is automatically recognised when entering that track with that **GPS Module** connected to **MXL**.

WARNING: **MXL** with **GPS Lap timer** manages signals coming from an optical receiver too. It is suggested to disconnect the traditional infrared receiver from **MXL** to avoid risk of lap times duplications.

1.6 – Data Visualisation

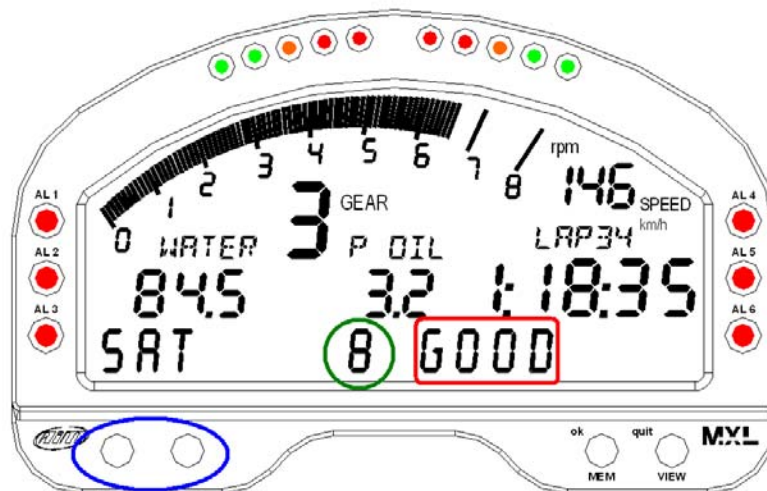

- Buttons to scroll channels and satellite status
- Number of received satellites
- GPS Status:
 - SEARCH = searching for satellites
 - WEAK = signal is weak;
 - GOOD = reception is ok

Note: “Channels” and “Satellite status” pages are scrolled using “<<” and “>>” buttons only if **MXL** bottom static string is disabled. Pay attention while configuring **MXL**. For further information refer to **Race Studio Configuration** user manual.

1.7 – Data download

Software and data download mode are the same of **MXL**.

2 – GPS Module and EVO3

2.1 – Connections and Power

To connect **GPS Module** to **EVO3** connect the logger to CAN cable labelled as EXP (Expansion). In case more CAN peripherals have to be connected, refer to the related paragraph of the previous chapter.

2.2 – Installation on the vehicle

GPS Module installation on the vehicle with **EVO3** is the same as **MXL** one. For a proper working of **GPS Module**, pay attention while installing it on the vehicle. Refer to the same paragraph in “**GPS Module** and **MXL**” chapter for further information.

2.3 – Configuration Wizard

No system configuration is needed. The systems self-configures at start up. It is suggested to switch on the system a few moments before entering the track.

2.4 – Data download

Software and data download mode are the same of **EVO3**.

3 – GPS Module and MyChron4

3.1 – Connection and power

GPS Module can be connected with **MyChron4** in different ways and with different peripherals.

3.1.1 – Connection with internal power

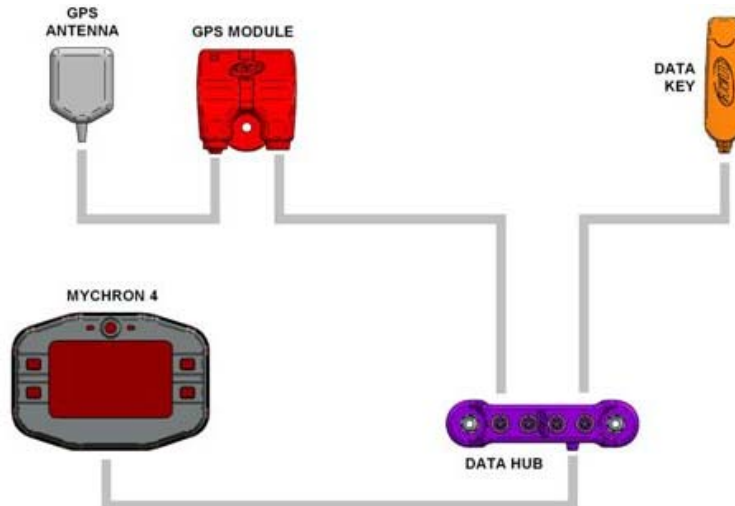

The figure above shows a CAN network powered by **MyChron4** internal batteries: this powering reduces network autonomy, valuable in around two hours recording time.

To connect **GPS Module** to **MyChron4** use the 5 pins back connector labelled as EXP shown here below.



3.1.2 – Connection with external power (recommended)

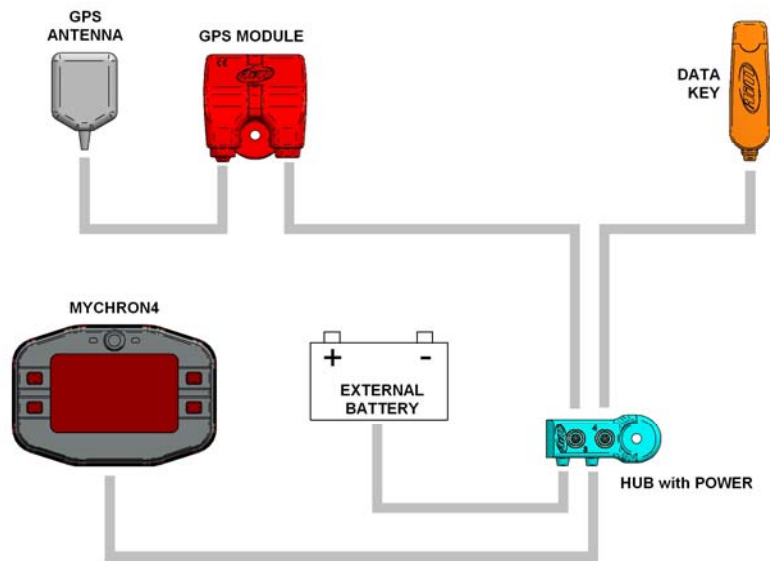

The figure below shows a CAN network where **GPS Module** and **MyChron4** are externally powered (assuming a 12 volts battery is available on TAG kart).

To connect **GPS Module** to **MyChron4** use the 5 pins back connector labelled as EXP shown here below.



3.1.3 – Connection on MyChron4 eBox with AIM Data Hub and external power

In the figure below, **eBox** is connected to **MyChron4** and interfaces directly with **GPS Module**.

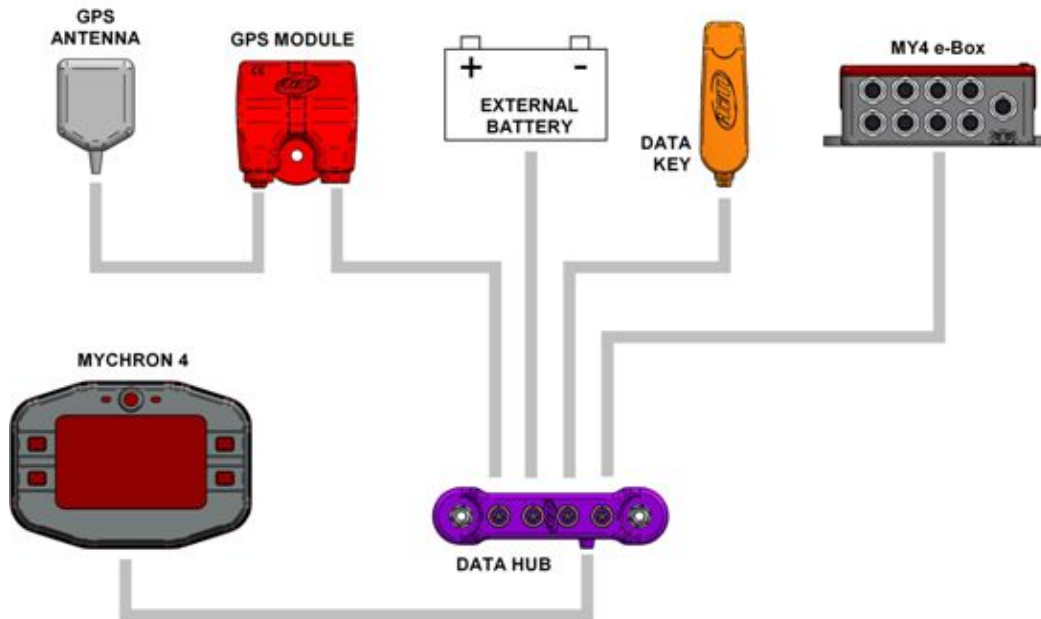

The all network is externally powered. It is recommended to leave **MyChron4** and **eBox** internal batteries at their place.

To connect **GPS Module** to **MyChron4** use the 5 pins back connector labelled as EXP shown here below.



3.2 – Installation on the vehicle

For **GPS Module** to work properly, pay attention while installing it on the vehicle. For a better reception, fix the GPS receiver to the floorpan and integral with it as in the figure below. Please fix **GPS Module** to the platform inserting a self-locking screw in the proper hole.



The GPS antenna has to be parallel to the ground to have a wider angle of view to the sky and to receive the maximum number of satellites correctly connected to the system: we would suggest to install it on the front number plate (see the photo below).



The number plate is made in plastic and the magnet cannot keep the antenna steady. For the optimum installation we would suggest to use a strip of Dual Lock – Velcro®. The antenna cable should pass on the kart front fairing along the fairing brackets to the **GPS Module** fixed on the platform as shown below.

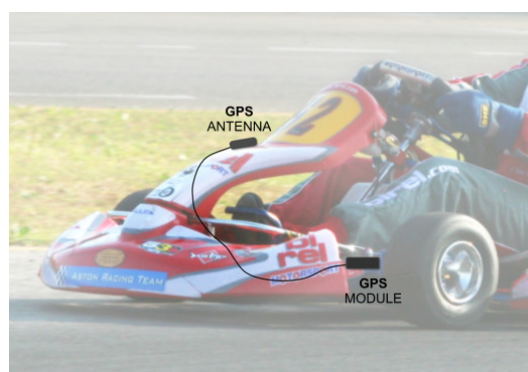

3.3 – Configuration Wizard

No system configuration is needed. The system self-configures at start up. It is suggested to switch on the system a few minutes before entering the track.

3.4 – The GPS Lap timer

This new feature allows the user to get lap and split times without using beacon transmitters nor optical/magnetic receiver. All is needed is a **GPS Module** connected to **MyChron4/MyChron4 2T** with **31.57.06 (or later) firmware version** installed.

3.4.1 – Preliminary operations

Before starting GPS setting, two preliminary operations are required.

First of all check and set the correct number of lap marker, start/finish line and splits, in **MyChron4** configuration. The maximum number of lap marker allowed is 5 (4 splits + start/finish line). For further information on this subject refer to the logger user manual.

The second preliminary operation is to set lap type in **MyChron4** configuration. Here below the two available options are shown.

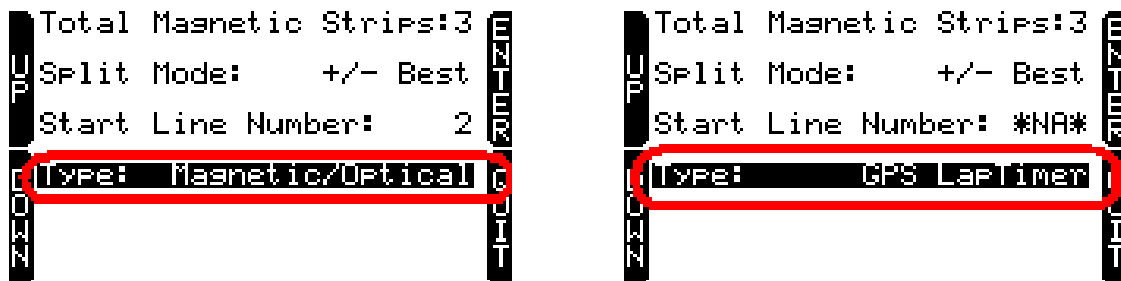

Selecting “GPS Laptimer” it is possible to leave the optical/magnetic receiver connected and the system will automatically disable it when **GPS Module** with lap timer function is connected.

If - for any reason - **GPS Module** is disconnected from the logger, the system will automatically switch to “Type: magnetic/Optical”.

3.4.2 – Setting GPS Laptimer

Once **MyChron4** is correctly configured it is necessary to go on the track to set lap and split positions giving correct instructions to the **GPS Module**. This allows it to get beacons.

Warning: this operation is required the first time entering the track and only once for each track.

To set lap/splits position switch **MyChron4** on and press ON/View button until “G.P.S. Data” page - shown below - appears:

```

G.P.S. DATA
N.SAT.    8    GOOD ****
                SPEED    0
-----
OK to Begin Settings
Press VIEW to Exit

```

Note: it may occur that at first the page shows “Initializing” in spite of “OK to begin settings”; just wait a few moments and the correct message appears.

To correctly set lap and split positions it is suggested to run the first track lap more slowly so to have enough time to enter the desired points of the track.

Press OK button to begin settings (or VIEW button to exit).

If the logger is **configured not to sample split times** this window appears:

```

G.P.S. DATA
N.SAT.    8    GOOD ****
                SPEED    0
-----
Press OK to Set Beacon
Press VIEW to Exit

```

To set Start/Finish line press OK button once reached the desired position on the track and Start/finish line position is saved (press VIEW button to exit).

If the logger is configured to record split times, their position is required by the system as shown below.

<pre>G.P.S. Data N.SAT. 8 GOOD **** SPEED 0</pre>	<pre>G.P.S. Data N.SAT. 8 GOOD **** SPEED 0</pre>
<pre>Press OK to Set Split #1 Press VIEW to Exit</pre>	<pre>Press OK to Set Split #2 Press VIEW to Exit</pre>

Many windows like these shown above will appear as many splits have been set. Once reached the desired split position confirm pressing OK button (press VIEW button to exit).

Once the configuration is over, the screen here below appears and the system is ready to acquire lap/split times.

```
G.P.S. Data
N.SAT. 8 GOOD ****
SPEED 0
Track Ok!
▶▶Track01 08/06/27 11:12
OK to Restart Settings
Press VIEW to Exit
```

Press "VIEW" button to exit setup or "OK" to restart settings.

Warning: do not set lap split markers under bridges or near to obstacles.

3.4.3 – Additional features and equivalent circuits management

GPS Module can record up to 50 track configurations with up to 5 splits for each track. Once the number of 50 tracks reached it is necessary to download data on a PC to manage more tracks. Once saved, the circuit will be automatically recognised when entering that track with **MyChron4** connected to that **GPS Module**.

"Track Ok!" message on the central part of the display means that the track has been recognized and the system is ready to get GPS lap and split times.

In case **GPS Module** detects more stored track within a radius of 5 km, **MyChron4** display shows this page:

```
G.P.S. Data
N.SAT. 8 GOOD ****
SPEED 0
Track Ok!
>> to View Tracks
OK to Restart Settings
Press VIEW to Exit
```



It informs that there are more tracks available and that it is possible to select the desired one.

Pressing “>>/OFF” button this window appears:



Use MENU/>> and “<</OFF” buttons to scroll the list and “MEM/OK” button to select a track. The system informs that the track has been selected with the symbol “▶▶” as shown here below.



In case **no choice is made** the logger automatically selects the track as follows:

- in case of two **physically different tracks** the system needs **one complete track lap** to correctly identify the track: sampled data will thereby be valid starting from the second complete track lap;
- in case of **more settings of the same track** the Module chooses the last one stored; the system needs **two complete laps** to verify the existence of more settings of the same track and distinguish the correct one; sampled data will thereby be valid starting from the third complete track lap.

Once a test session is over, it is possible to verify the automatic choice made by the system entering “Track visualisation” page: press several times “>>/OFF” button.

Warning: to verify the track selected by the logger do not switch the logger off.

3.4.4 – Troubleshooting

If the screen shows: **"Bad Setting, please Restart"**: the beacon setting procedure did not end correctly and needs to be restarted. Press "ON/VIEW" button and restart the procedure.

```

GPS Data
N. SAT. 8 GOOD ****
SPEED 0

Bad Settings, please Restart
Press VIEW to Exit
  
```

If the screen shows: **"GPS LapTimer Initializing"**: simply wait a few seconds.

```

GPS Data
N. SAT. 7 Search...
SPEED 0

GPS LapTimer Initializing
  
```

If the screen shows **"GPS Tracks Memory Full"**: GPS Tracks Memory is full; it is necessary to save the tracks and erase the memory using **GPS Manager** software.

```

GPS Data
N. SAT. 9 GOOD ****
SPEED 0

GPS MEMORY FULL
  
```

In case the screen shows **"GPS OFF"**: the GPS is Off (CAN connection is broken); wait for a few seconds and everything will come back ok. If this message is shown for more than 10 seconds it is suggested to check CAN connection or to switch off/on the engine.

```

GPS Data
N. SAT. 9 GOOD ****
SPEED 0

GPS OFF
  
```

In case the screen shows **"GPS FW must be Upgraded"** it is necessary to upgrade GPS firmware (correct versions are **from 35.14 onward**).

```

GPS Data
N. SAT. 9 GOOD ****
MEMORY SPEED 0

GPS FW must be Upgraded
  
```

3.5 – MyChron4: Data visualisation

When **GPS Module** is connected to **MyChron4**, switching the logger on **GPS Module** recognition window appears.

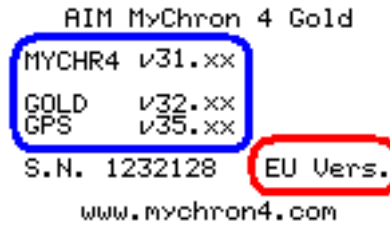

- **MyChron4, eBox Gold** and GPS Firmware versions
- EU = European version; USA = American Version

3.5.1 – Data visualisation while recording

Pressing “ON/VIEW” button, **MyChron4** display shows, under the RPM bar graph, GPS speed value with the related unit of measure (kmh/mph). Pressing again “ON/VIEW” button the following window appears:



- Number of received satellites
- GPS Status:
 - SEARCH=searching for satellites
 - BAD=reception is bad;
 - WEAK=signal is weak;
 - GOOD=reception is ok
- GPS Speed

To come back to the first page, click twice “ON/VIEW” button.

3.5.2 – Data visualization during data recall

The logger shows some additional information (please refer to **MyChron4** user manual for further information):

“Session summary” page shows max GPS speed peak of the test.

20/01/08 Test 9 Laps 16					
MAX	RPM	SPD	ET1	ET2	
19464		121	50	562	
LAP		TIME	RPM	ET1	MAX
13		0:44.56	19301		38°C
			6666		
9		0:44.69	19402		39°C
			7824		
12		0:44.86	19410		39°C
			6782		

“Splits of selected lap” page shows max and min peaks of GPS speed of the lap.

TEST 9 LAP 13		00:44.56
LONATO		1# 00:21.03
		2# 00:14.15
20/01/08		3# 00:09.38
14:50		
RPM	SPD	ET1 ET2
19301	120	38 562
6666	51	37 452

3.6 – MyChron4 Data key for data download

Software, Data key working mode and data download are the same of **MyChron4**. Please refer to **MyChron4** user manual for further information.

4 – GPS Module and MyChron4 660

4.1 – How to connect GPS Module

GPS Module can be connected to **MyChron4 660** in different ways and with different peripherals.

4.1.1 – Connection with internal power.

The figure below shows a CAN network powered by **MyChron4 660** internal batteries: this powering reduces the network autonomy, valuable in around two hours recording time.

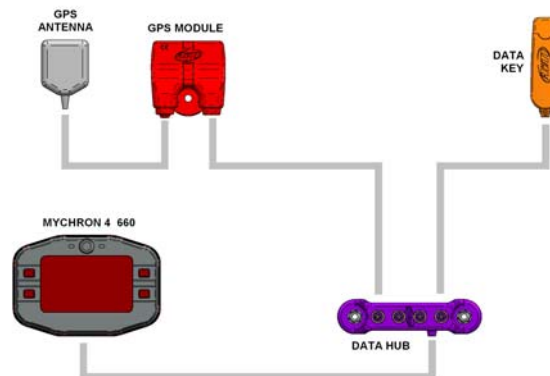

To connect **GPS Module** to **MyChron4 660** use the 5 pins back connector labelled as EXP shown here below.



4.1.2 – Connection with external power (recommended)

The figure below shows a CAN network where **GPS Module** and **MyChron4 660** are externally powered (assuming a 12 Volts battery is available on Junior Dragster).

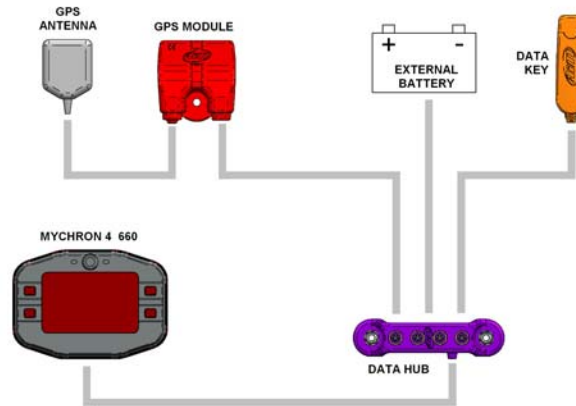

To connect **GPS Module** to **MyChron4 660** use the 5 pins back connector labelled as EXP shown here below.



4.2 – How to install GPS Module

For a better reception fix the GPS Antenna over the cockpit, parallel to the ground so to have a wider angle of view to the sky and to receive a maximum number of satellites correctly connected to the system. The GPS receiver, on the contrary, must be fixed through the implantation hole as in the figure below.

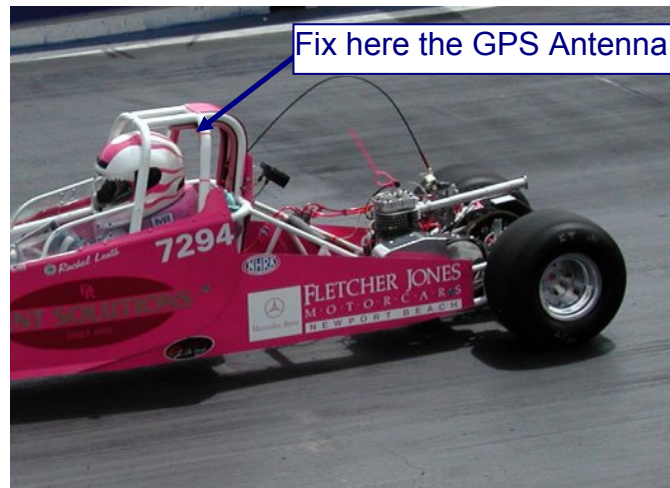

4.3 – Configuration Wizard

No system configuration is needed. The system self configures at start up. It is suggested to switch on the system a few moments before entering the track.

4.4 – MyChron4 660 Data visualization

When **GPS Module** is connected to **MyChron4 660**, switching on the data logger, **GPS Module** recognition window appears.

```

AIM MyChron 4 - 660
M4-660 vxx.xx.xx
G.P.S. vxx.xx
S.N. 877777 USA Vers.
www.mychron4.com
  
```

- **MyChron4 660** and GPS Firmware version
- USA =American Version / EU = European Version

Pressing “ON/VIEW” button, **MyChron4 660** display shows, under the RPM bar graph, GPS speed value with the related unit of measure (KM; MPH).

Pressing again “ON/VIEW” button the following screen appears:



- Numbers of received satellites
- GPS Status
 - SEARCH searching for satellites
 - BAD reception is bad
 - WEAK signal is weak
 - GOOD reception is OK
- GPS Speed

To come back to the first page click twice “ON/VIEW” button.

4.5 – MyChron4 660 Data key for data download

To download recorded data on your PC refer to **MyChron4 660** user manual.

4.6 – GPS Module with QMA

Open a test containing GPS data with **QMA** software, some additional channels are shown:

<input type="checkbox"/>	RPM	■		rpm	...
<input type="checkbox"/>	EGT	■		°F	...
<input type="checkbox"/>	SHAFT	■		rpm	...
<input type="checkbox"/>	CHT	■		°F	...
<input type="checkbox"/>	Speed	■		mph	...
<input type="checkbox"/>	CVT	■			...
<input type="checkbox"/>	Drive	■		%	...
<input type="checkbox"/>	Linear	■		g	...
<input type="checkbox"/>	Battery	■		V	...
<input type="checkbox"/>	GPS_Speed	■		mph	...
<input type="checkbox"/>	GPS_Nsat	■		#	...
<input type="checkbox"/>	GPS_LatAcc	■		g	...
<input type="checkbox"/>	GPS_LonAcc	■		g	...
<input type="checkbox"/>	GPS_Slope	■		deg	...
<input type="checkbox"/>	GPS_Heading	■		deg	...
<input type="checkbox"/>	GPS_Gyro	■		deg/s	...
<input type="checkbox"/>	LoggerT	■		°F	...

GPS Speed

Speed measured through GPS signal

GPS Nsat

Number of satellites locked to **GPS Module**. Max accepted number of satellites is 9. Better accuracy is obtained with between 6 and 9 satellites locked.

GPS Lat.Acc.

Lateral acceleration compared to the trajectory computed through GPS speed along the three axis.

GPS Lon.Acc.

Vehicle accelerations and decelerations

GPS Slope

Positive and negative slope of the track

GPS Heading

Route of the vehicle compared to the geographical North

GPS Gyro

Yaw speed in degrees per second

5 – GPS Manager software

Thanks to **GPS Module** it is possible to create lap and split signals in any point of the track. Through this software **GPS Module** can be synchronized with the PC. With GPS Manager it is possible to:

- Move lap/split configurations from **GPS Module** database to PC one
- Move lap/splits configurations from PC database to **GPS Module** one.

The figure below shows GPS Manager main window.

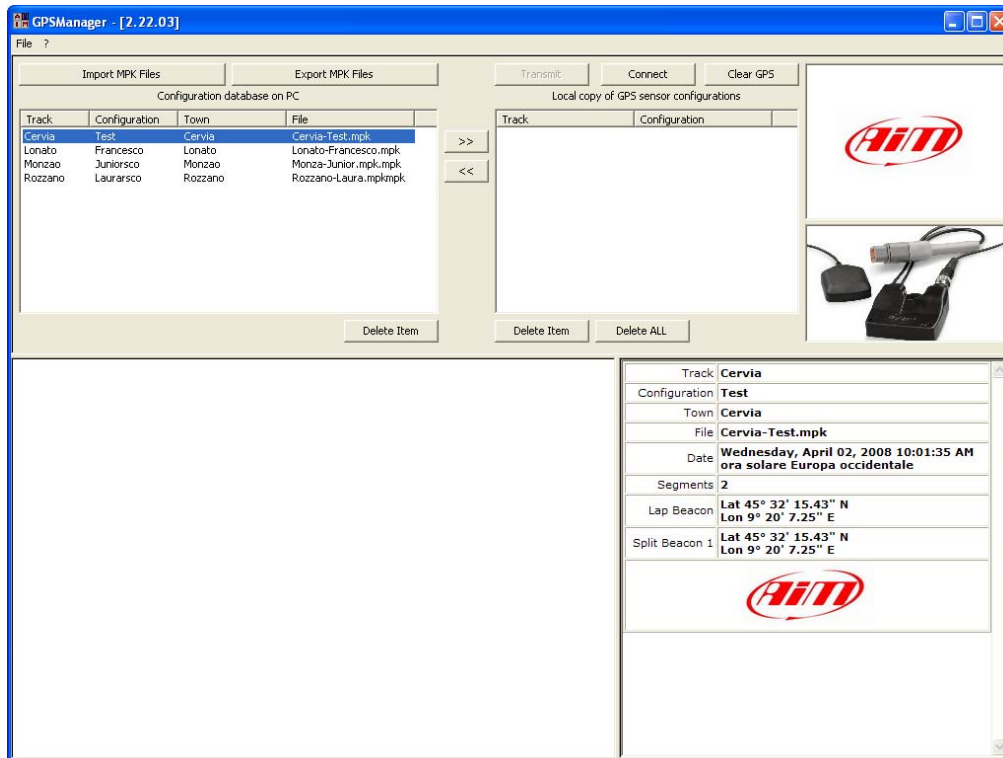

Top left is "Configuration database on PC" window, more in detail below; it shows a list of all the available track configurations. This list is automatically loaded when the software is run.

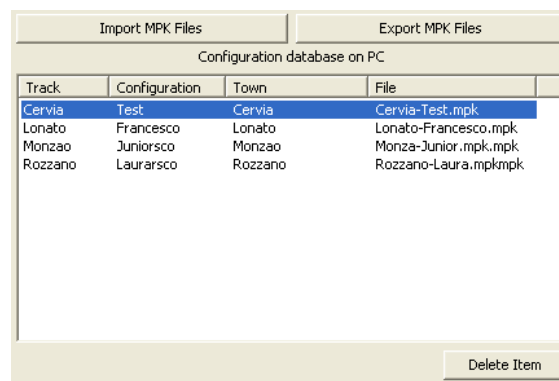

Over this window are two buttons:

"Import MPK files": imports a configuration in the PC database from a file

"Export MPK files": exports a configuration from the PC database to a file.

On bottom of the window is "Delete Item" button, that allows you to delete one by one the configurations from the PC database.

Between the windows that show configurations on the PC and locally on the GPS, are two displacement buttons used to move the configurations from the PC database to the **GPS Module** one and vice versa.



“>>” button moves the configurations from the PC Database to **GPS Module** one

“<<” button moves the configurations from the **GPS Module** Database to the PC one.

Please note: the configuration is moved from one database to the other only in the software: GPS Module is really synchronized only when “Transmit” button is pressed.

Moving of a configuration from **GPS Module** database to PC one can lead to three different situations:

- the configuration has just been created on the **GPS Module**: the system asks for track and configuration names; filling in the window the configuration is copied in the database;
- the configuration on **GPS Module** has already been copied in the PC database; the system asks for the name of the configuration: filling in the window, and pressing “OK” button the new configuration is inserted in the PC database;
- the configuration on **GPS Module** has a name but there is no copy of it in the PC Database. Pressing “OK” button a new configuration is inserted in the PC Database.

The picture below shows the window where to insert track name and track configuration name.

File name is by default set as track name + configuration name; enable “File Name” checkbox to inserts a custom file name.

Town name is by default set as track; check “Town” checkbox to filling a custom name.

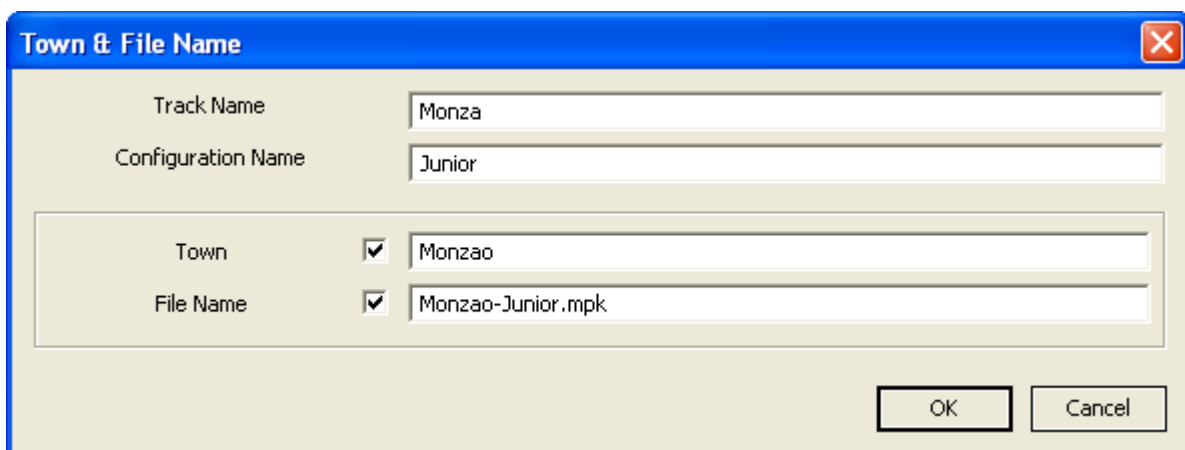

The screenshot shows a dialog box titled "Town & File Name". It has a blue title bar with a close button (X) on the right. The dialog contains the following fields and controls:

- Track Name: Text box containing "Monza".
- Configuration Name: Text box containing "Junior".
- Town: A checkbox that is checked, followed by a text box containing "Monzao".
- File Name: A checkbox that is checked, followed by a text box containing "Monzao-Junior.mpk".
- At the bottom right, there are two buttons: "OK" and "Cancel".

Top central is “Local copy of GPS sensor configurations” window, shown below, that contains a list of all track configurations stocked in the **GPS Module** memory. This list is loaded on demand.



Over this window are three buttons.



- “Transmit” button copies the configurations from the **GPS Module** list into the **GPS Module** memory. The user receives a confirmation message because this operation modifies the memory of the **Module**.
- “Connect” button loads the **GPS Module** list. The software copies in the list all configurations of the Module memory.
- “Clear GPS” button completely erases the Module memory. The user receives a confirmation message because this operation completely erases the GPS memory.

Under this window are two buttons.



“Delete Item” button deletes one by one the configurations from the GPS database.

“Delete ALL” button deletes all the configurations from the GPS database.

Warning: pressing this button configurations are deleted only from the local copy of GPS memory. Only pressing “Transmission” button GPS Module Memory is really deleted.

Top right are two windows: AIM logo over and **GPS Module** below. When **GPS Module** is connected to an AIM logger AIM logo is replaced by an image of that logger. The system tells that **GPS Module** is correctly communicating with that logger.



5.1 – Typical use of GPS Manager

Typical use of **GPS Manager** software implies going on the track with **GPS Module** connected to AIM logger and setting lap and splits (if configured). Afterwards **GPS Module** can record lap and split times of the track forever.

To copy lap/splits configuration from one **GPS Module** to another,:

- Connect **GPS Module** (1) to the PC
- Run **GPS Manager** software
- Press “Connect” button
- Press “<<” button to copy the configuration in the PC database
- Disconnect **GPS Module** (1) from the PC
- Connect **GPS Module** (2) to the PC
- Press “Connect” button
- Press “>>” button to copy the configuration from the PC database to the local copy of **GPS Module** configurations
- Press “Transmit” button.

6 – GPS Module data analysis

Opening a test containing GPS data with **Race Studio Analysis** software some additional channels are shown:

- GPS Speed;
- GPS Nsat;
- GPS LatAcc;
- GPS LonAcc;
- GPS Slope;
- GPS Heading;
- GPS Gyro;

GPS Speed

Speed measured through GPS signal.

GPS Nsat

Number of connected satellites. Maximum allowed satellites is 9. Better accuracy is obtained receiving between 6 and 9 satellites.

GPS Lat Acc

Lateral acceleration compared with the trajectory computed using GPS speed along the three axes.

GPS LonAcc

Vehicle accelerations and decelerations.

GPS Slope

Track positive and negative slope.

GPS Heading

Vehicle trajectory compared with the geographical North.

GPS Gyro

Yaw speed in degrees per second.

Selecting “View/GPS Data” on the menu bar the window showing the run trajectory appears.

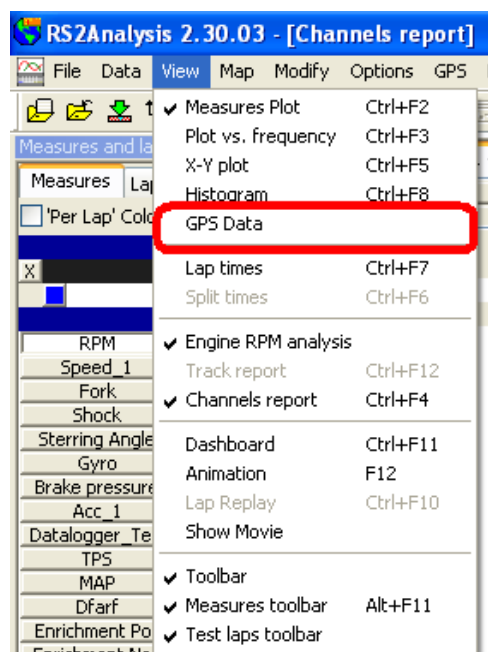

The same function can be activated through the proper icon on the toolbar.

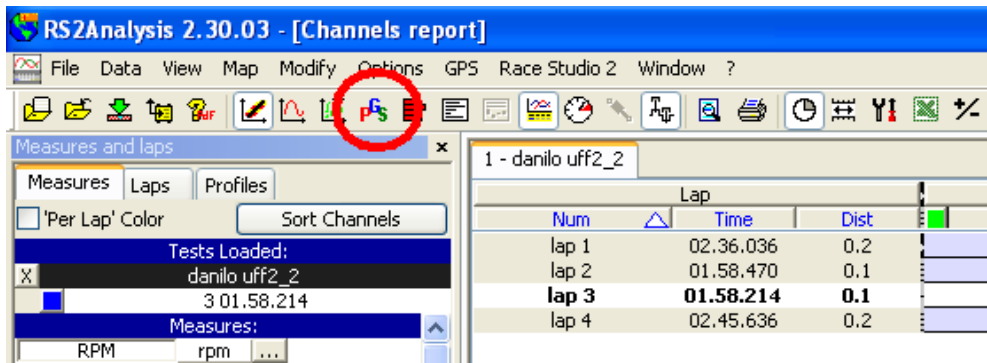

To modify graph and shown channels settings it is necessary to activate “Color Channel settings” window. This can be done in three ways:

- using menu bar: Modify/ Channel Colour;
- pressing the related icon (circled and highlighted by an arrow in the image below) on the toolbar;
- clicking on the coloured button on the left of the window (highlighted by a red box in the figure below)



6.1 – Settings GPS channels graphic view

The image below shows “Colour Channel Settings” window.

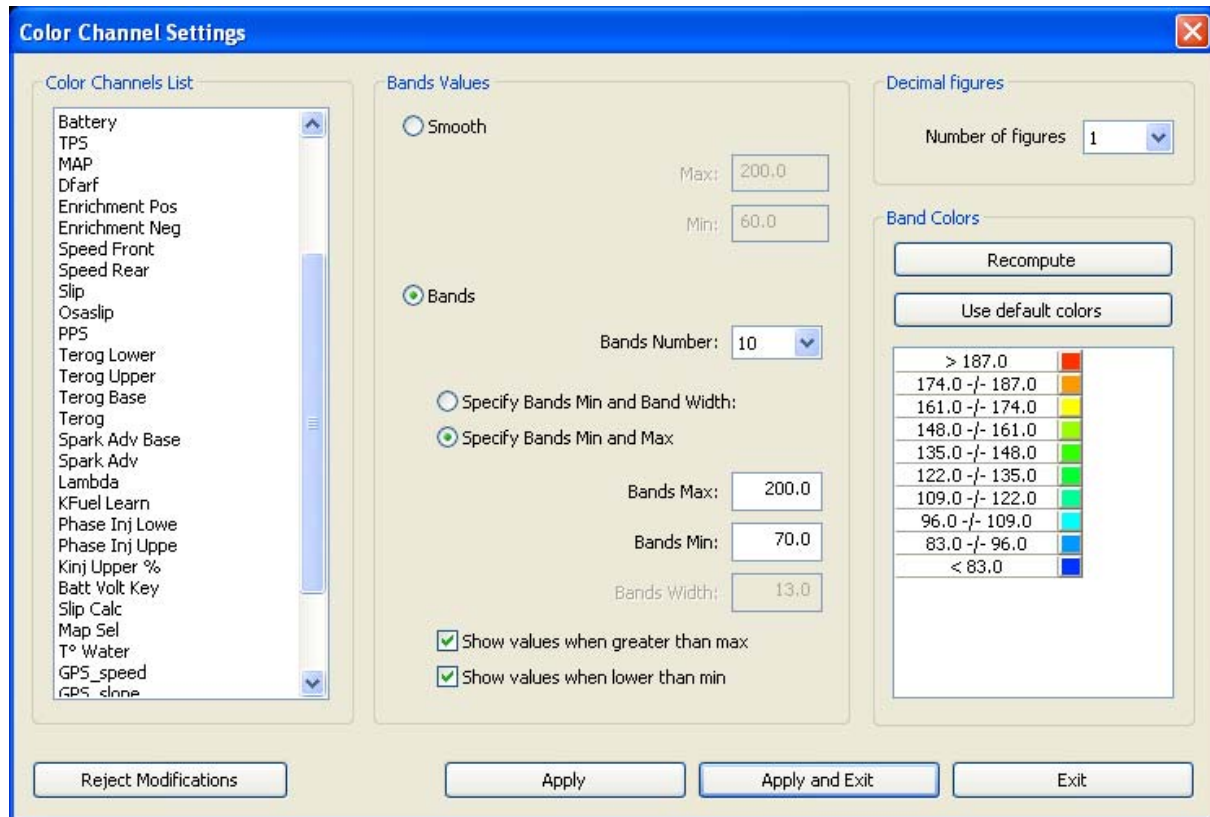

This window allows the user to set the visualization of GPS data on the graph. It is made up of various parts, explained here below.

6.1.1 – Colour channel list

This panel allows the user to select the channel to set.

6.1.2 – Bands values

This panel allows to practically select how to show GPS data.

The first choice to make is between “Smooth” and “Bands”.

Smooth visualisation - shown below - asks the user to set Max and Min value and shows GPS value in the graph with a continuous colour gradient.



Selecting **Bands** visualisation it is necessary to set some parameters that will make the software show GPS data using bands and with no colour gradients.

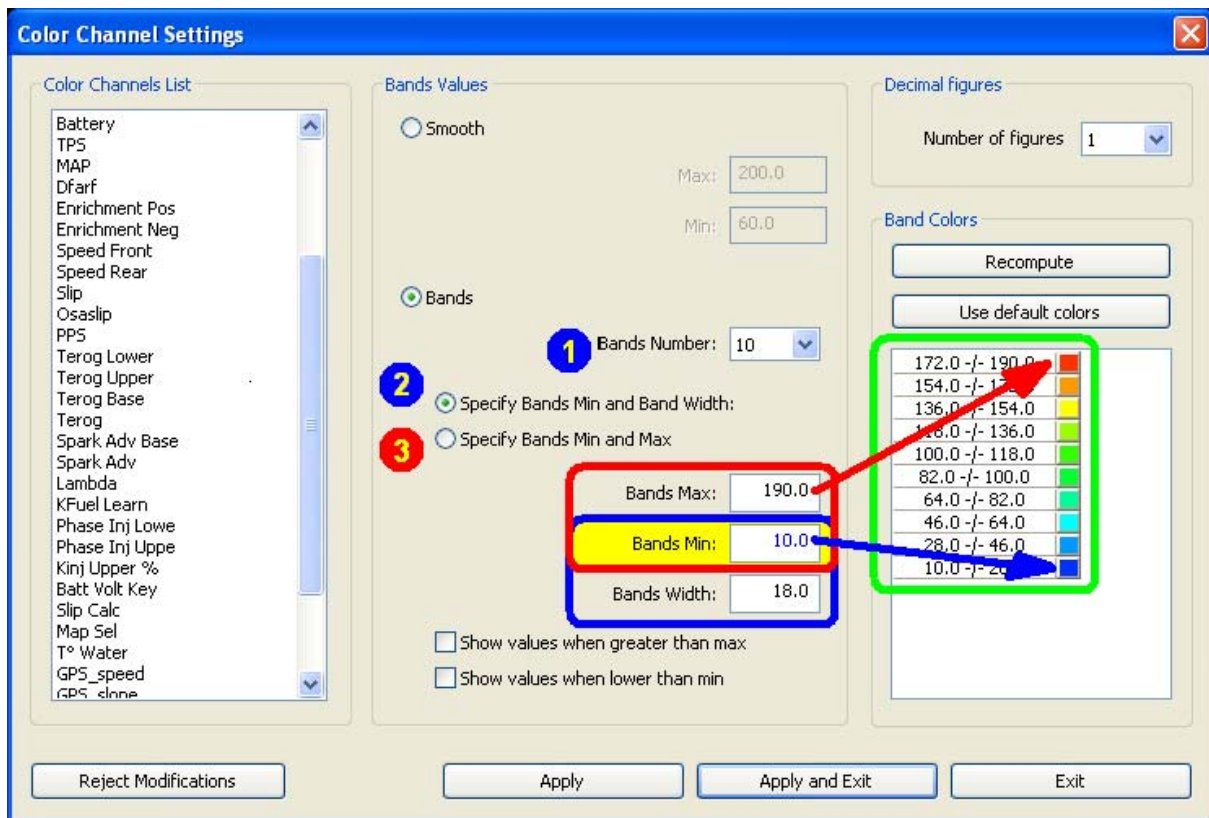

The first operation to perform is choosing number of Bands (1) – accepted values from 3 to 10 – to divide the value range by. A corresponding number of coloured boxes appears in the panel “Bands colours” on the right of the window (green circled).

Afterwards it is required to choose one of the options under this first one.

- Specify Bands Min and band width [(2) – bleu]: Bands Min corresponds to the low scale value that is associated with a colour selectable clicking on the coloured box beside the value in the green circled panel. Bands width corresponds to the value of one band.
- Specify Bands Min and Max (3): Bands Min corresponds to the low scale value that is associated with a colour, selectable clicking on the coloured box beside the value in the green circled panel. Bands Max corresponds to the high scale value that is associated with a colour, selectable clicking on the coloured box beside the value in the green circled panel. In this case the software computes each band value using the set Bands number (1)

When the type of visualisation has been set it is possible to decide if showing or not values greater than the max one and lower than the min one.

These options actually affect the graph layout because deciding not to show values greater than the max one and lower than the min one tracks sections involved in these values are hidden.

The images below show a situation where only values lower than the min one are shown. Max values band (first row in the right box) shows only the range of values between the penultimate band value and max value and values higher than the max one are hidden in the map (parts yellow circled in the figure below); the band of values lower than the min one (last row of the right box), on the contrary has no defined range.

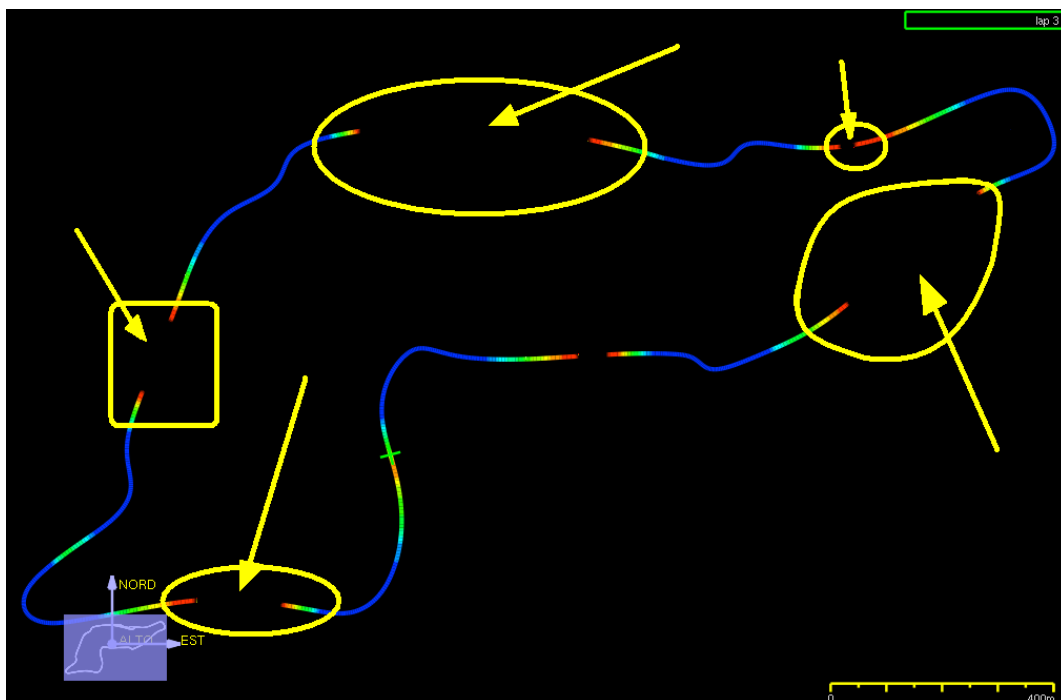
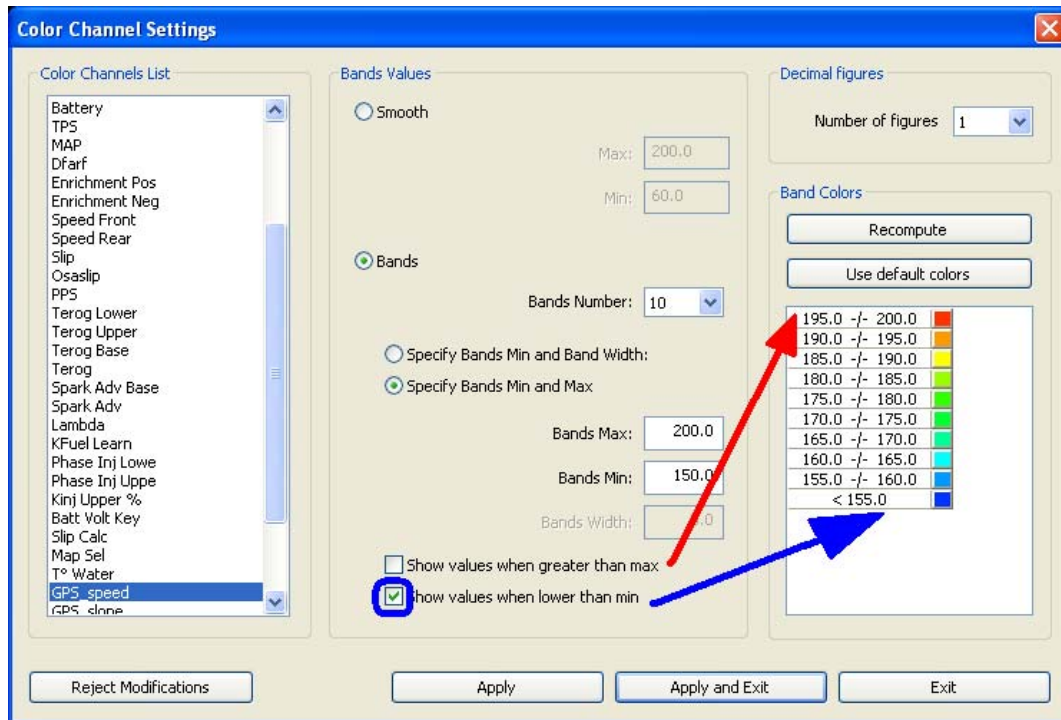

WARNING: when the parameters have been set it is necessary to press "Recompute" button in "Bands colour" panel and "Apply and Exit" button on the bottom keyboard to really modify the graph.

“Decimal figures” panel, shown below, allows to set the number of decimal figures to show for the selected channel.

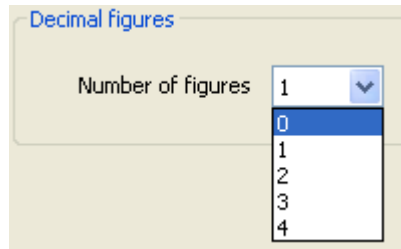

6.2 – Race Studio Analysis software – Other functions

Positioning the mouse on the trajectory, the punctual value of the measure in that point is shown.

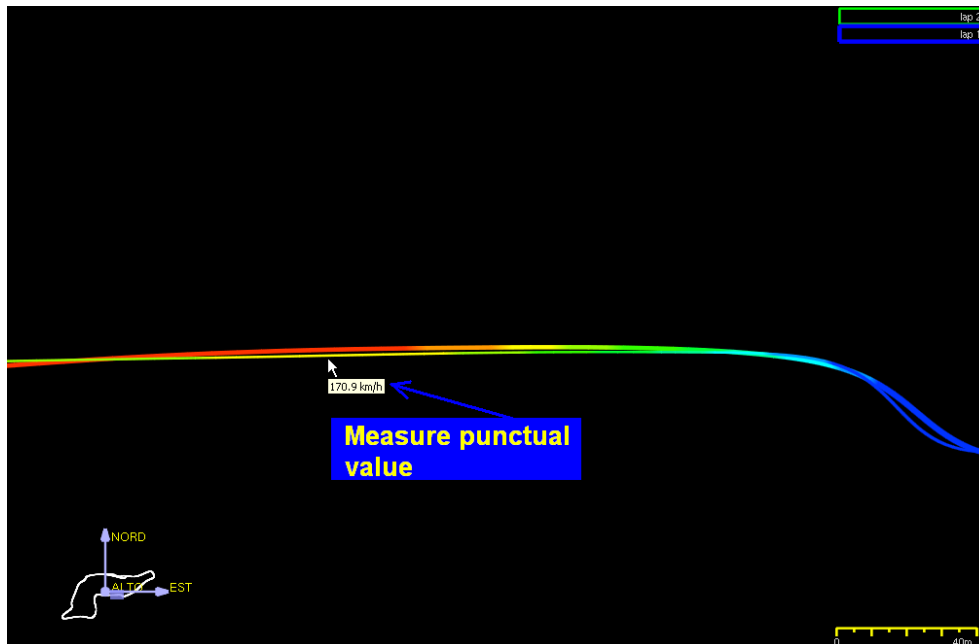

To activate a lap it is necessary to enable the related checkbox in “Test laps” bar on the bottom part of the software window (the figure below shows lap 4 activated).

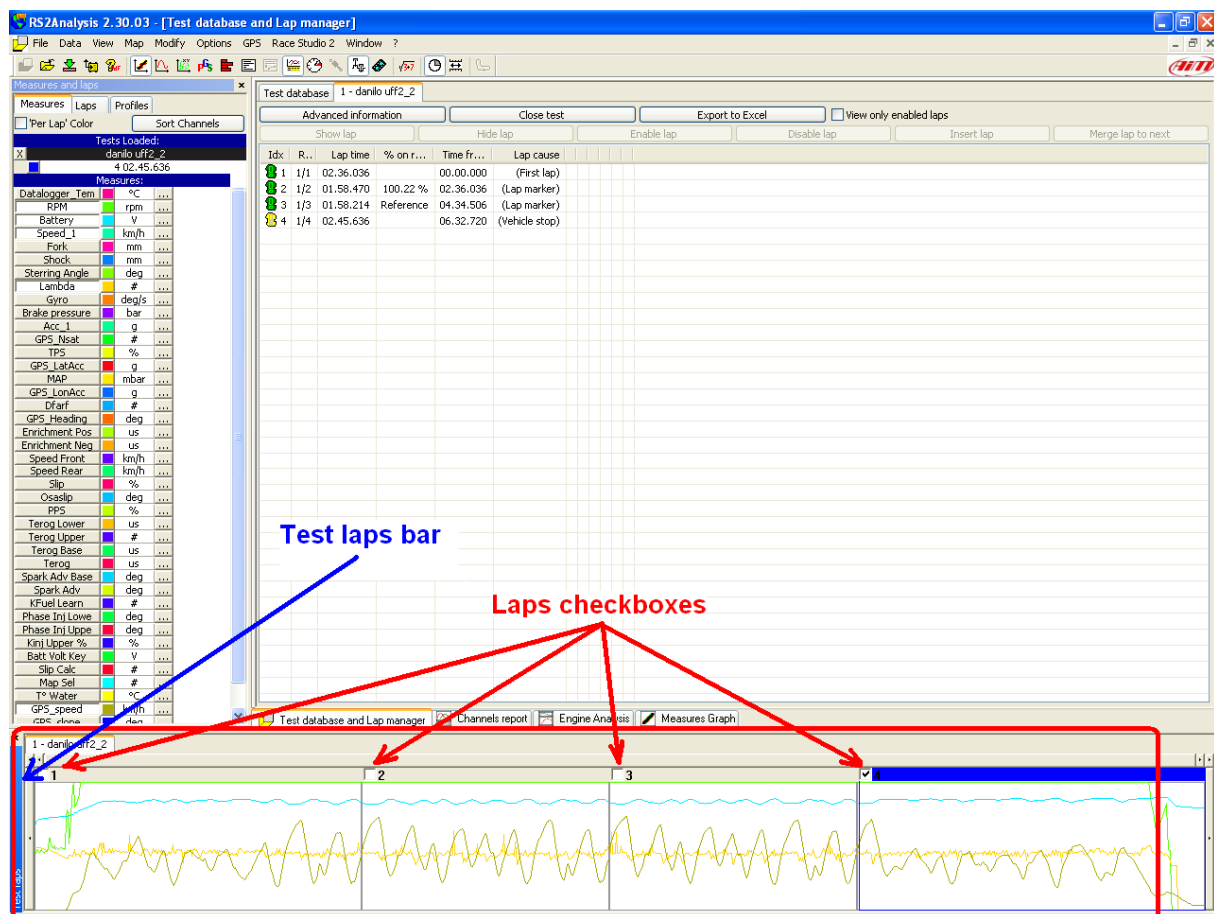

To better compare more laps it is suggested to enable “Per Lap” colour checkbox shown below in software Measures bar. It gives a colour to each lap.

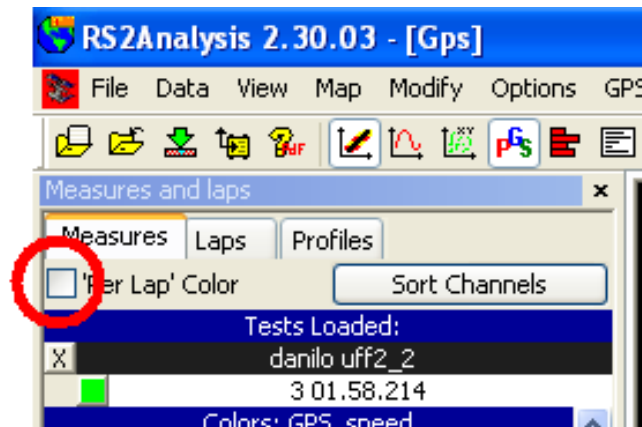

Like in measures graphs, in GPS data analysis too, it is possible to zoom in and out the graph to better analyze a point of the track; use the proper icons placed on the toolbar.



It is also possible to rotate the map along the three axes keeping mouse right button pressed and mouse pointer on the track view.

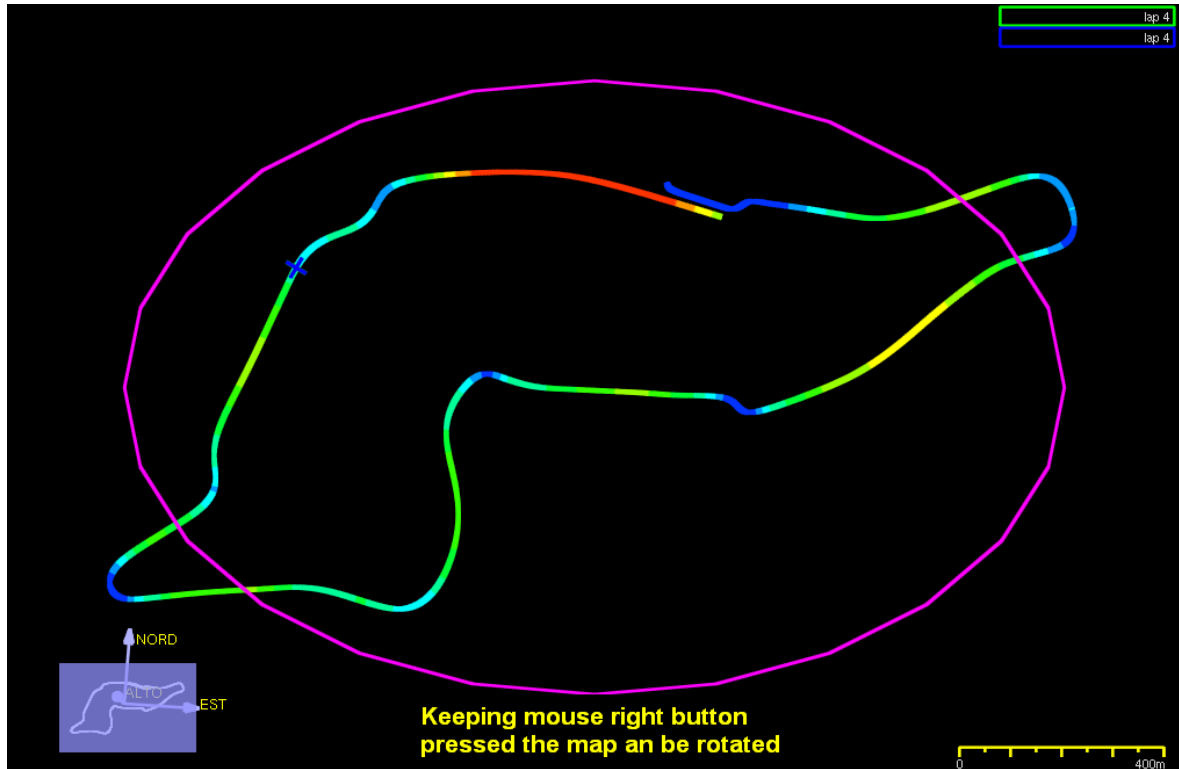

The map is created in three dimensions and it is thereby possible to show it laterally to detect altimetric variations.

These variations are shown double clicking with the mouse right button and keeping the pointer on the GPS map.

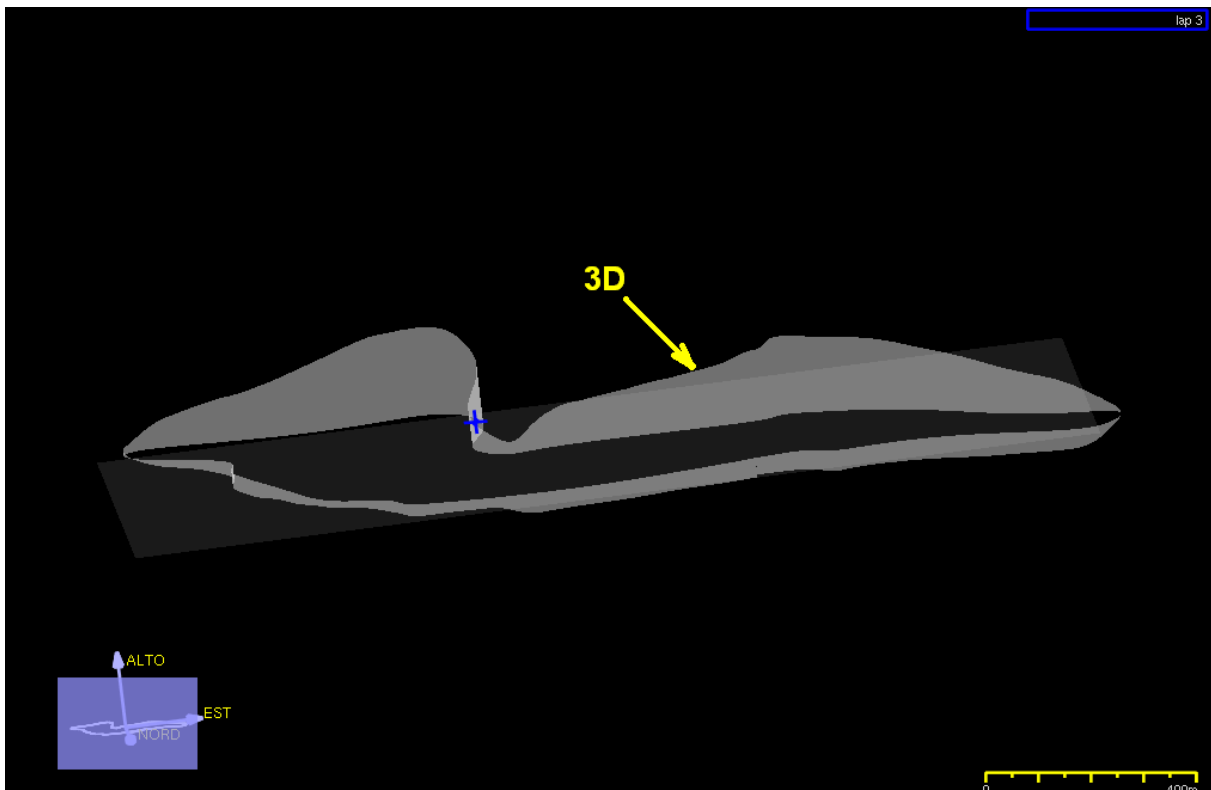

To better analyse the track it is possible to show a grid using the related icon placed on the toolbar.

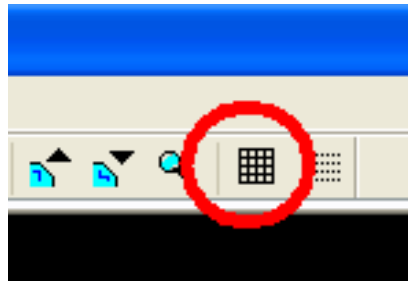

Grid settings can be modified following this path GPS ► Grid Settings.

Another usefull function is the possibility of creating an export file for Google Earth® following this path File ► Export KML file for Google Earth™.

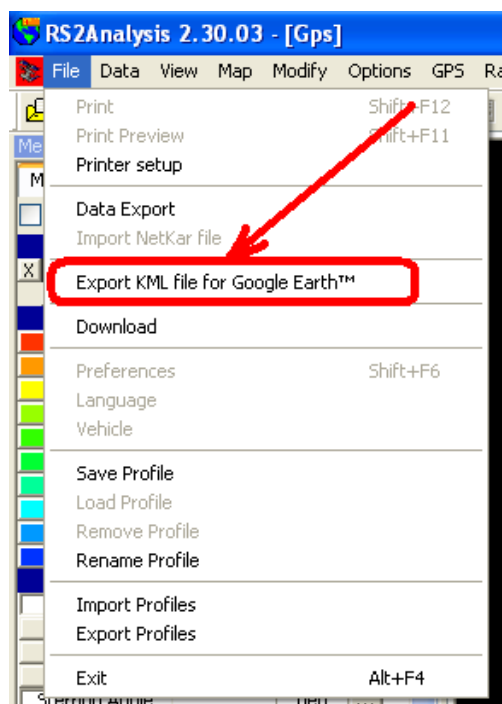

Opening the file double clicking on it, Google Earth® (if installed) is automatically run and the circuit is shown following the software spatial coordinates.



7 – Keep in touch!

To receive in real time all GPS software updating and all information concerning AIM products and accessory just e-mail: info@aim-sportline.com specifying the product categories of interest (car, bike or kart).

Appendix – Part numbers

GPS Module part numbers are:

- **X40GPS3BM125**: GPS Module with **antenna cable length 125 cm**
- **X40GPS3BM400**: GPS Module with **antenna cable length 400 cm**

GPS Module extension cables part numbers are:

- **V02552690**: extension cable length 50 cm
- **V02552700**: extension cable length 100 cm
- **V02552710**: extension cable length 150 cm
- **V02552720**: extension cable length 200 cm.