

# LCU-ONE CAN + Analog

## User Manual



## INDEX

<b>1 – LCU-ONE CAN + Analog description .....</b>	<b>2</b>
<b>2 – LCU-ONE mounting .....</b>	<b>3</b>
<b>3 – LCU-ONE power.....</b>	<b>3</b>
<b>4 – Lambda probe mounting.....</b>	<b>4</b>
<b>5 – LCU-ONE connection .....</b>	<b>5</b>
5.1 – Analog Connection .....	5
5.2 – CAN Connection .....	6
<b>6 – LCU-ONE Configuration.....</b>	<b>8</b>
6.1 – LCU-ONE standard analogue configuration .....	8
6.2 – LCU-ONE Analog configuration .....	11
6.2.1 – Preliminary operation.....	12
6.2.2 – Lambda controller Configuration.....	12
6.2.3 – The keyboard .....	15
6.2.4 – Informative panels .....	16
6.2.5 – The analog output graph.....	17
6.2.6 – Online values from Lambda controller.....	18
6.3 – LCU-ONE CAN configuration .....	19
<b>7 – Data visualisation on MXL/EVO3.....</b>	<b>25</b>
7.1 – Data visualisation on MXL.....	25
7.2 – Data visualisation on EVO3 .....	25
<b>8 – Data analysis with Race Studio Analysis .....</b>	<b>26</b>
<b>Appendix – Part numbers and technical drawings.....</b>	<b>27</b>
“A” – Part number of LCU-ONE CAN+Analog complete kit.....	27
“B” – Spare parts.....	27
“B” – Technical drawings.....	28

## 1 – LCU-ONE CAN + Analog description

**LCU-ONE CAN+Analog** (from here onward **LCU-ONE**) is a lambda controller for wide band BOSCH LSU 4.9 lambda probe. It fits petrol and diesel engines as well as alcohol based fuel engines. It is intended to check lambda probe proper working as well as to transmit Air/Fuel Ratio values or Lambda values both through the CAN bus or through a serial RS232 bus.

**Lambda value is defined as the ratio between instant AFR and Stoichiometric AFR, to say:**

**LAMBDA = (A/F)/(A/F) Stoichiometric**

where:

**A** = incoming part of air;

**F** = parts of petrol the carburetor injects into the engine;

**A Stoichiometric / F Stoichiometric** = parts of air needed to burn Stoichiometric F;

For gasoline i.e. it needs 14,57 parts of air to completely burn a part of gasoline, obtaining Lambda value=1 read by the probe.

**LCU-ONE** controller can detect lambda values in a range of 0.65 to 1.6 (free air).

**It is reminded that a lambda value lower than 1 means a rich mixture while a lambda value higher than 1 means a lean mixture.**

Wide band Lambda probe needs to be heated to work properly and not being poisoned with exhausted gas; **LCU-ONE** precisely manages the probe heater so to keep temperature values in the optimum working range.

If using the CAN bus, **LCU-ONE** supplies information about the probe temperature and a diagnostic highlighting improper functioning situations of the same probe (probe not connected, GND short circuit, power short circuit).

Lambda value is supplied through a 0-5 Volts analog output configurable through **Lambda Configurator**, the software properly developed by AIM to configure its analog controllers.

On the other hand Lambda/AFR value, as well as probe temperature and diagnostics, comes through the CAN bus.

**Lambda probe used with LCU-ONE becomes very hot (around 700-800 °C, 1291-1472 °F); it is thereby necessary **AVOIDING:****

touching it

placing it in contact with flammable stuff or fuel.

**Warning:**  
**disrespect of those precautions, can cause shocks, burnings or explosions.**

## 2 – LCU-ONE mounting

Install **LCU-ONE** in a flat location and far from heat sources. Install it steady using the lateral fixing holes.

Arrange the wiring in the engine compartment or in the cockpit paying attention not to let them pass close to heat sources.

If using the CAN bus, remember that CAN cable needs to be terminated with an appropriate resistance. This is why the kit includes the terminator inserted in the Deutsch connector plug.

## 3 – LCU-ONE power

To work properly, **LCU-ONE** needs an external power (between 10 and 15 volts).

It manages the probe heater, that needs 15-20 watt power.

**Ensure that LCU-ONE is powered by the vehicle master switch so to avoid it absorbing power from the battery when the engine is off.**

To power **LCU-ONE** follow this scheme:

**GND cable** (black): connect it to vehicle GND (battery negative pole suggested).

**power cable** (red): connect it to an external 12 volt power source through the vehicle master switch and **protected with an (at least) 5 ampere fuse.**

**In case power cable needs to be extended, use cables whose section is at least 1,34 mm<sup>2</sup>.**

## 4 – Lambda probe mounting

Install **LCU-ONE** in a flat location and far from heat sources; install it steady using the supplied bracket.

Arrange the wiring so to avoid it passing close to heat sources.

BOSCH LSU 4.9 Lambda probe is to be installed on the vehicle exhaust pipe using a specific adaptor supplied with the kit and is to be welded on the same pipe. The probe should be sufficiently near to the engine.

Probe working temperature should not exceed 900°C (1652°F) and the same probe should not be exposed to the free flame coming from the exhaust system.

Probe installation angle should be of at least 10° to avoid liquid stuff to come in contact with the probe, polluting it.

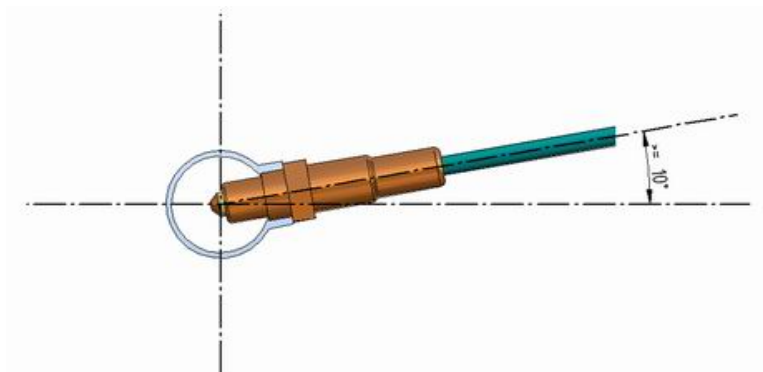

Once the probe is installed, pay attention not to let the cable pass near to excessively heated sources (the exhaust pipe for example).

Bosch LSU 4.9 probe auto-calibrates (no calibration is thereby required to the user).

**Do not use solvents or additives to clean the probe connector. It is suggested to remove the probe when cleaning the vehicle so to avoid polluting it with detergents.**

Never switch the vehicle on with Lambda probe installed and not connected to a correctly working **LCU-ONE** controller: a probe not heated and exposed to exhaust gas would be irremediably damaged.

**N.B. BOSCH LSU 4.9 Lambda probe has been designed and developed to be used with unleaded or diesel engine. It can be used with other kind of engines too but its duration needs to be verified by the user with specific tests.**

## 5 – LCU-ONE connection

### 5.1 – Analog Connection

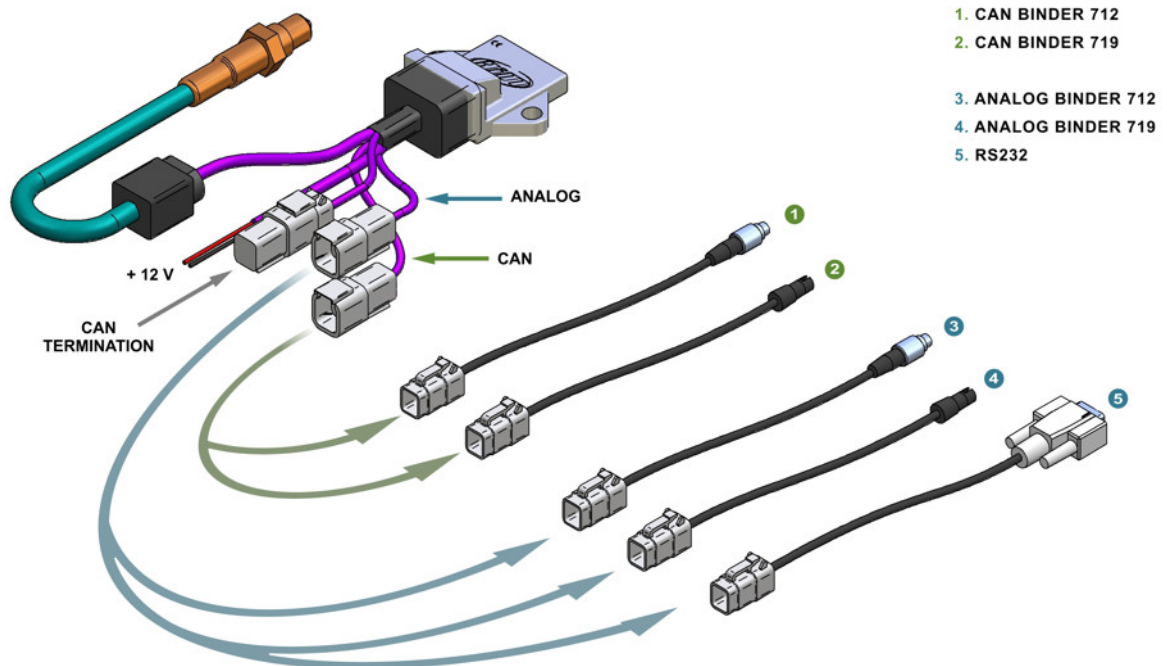

Refer to the image above to make an **LCU-ONE** analog connection. Extensions labelled as “3” and “4” are to be used to interface **LCU-ONE** with AIM loggers, while extension labelled as “5” is to be used for serial programming. Refer to this tutorial appendix for items part numbers and connectors pinout.

## 5.2 – CAN Connection

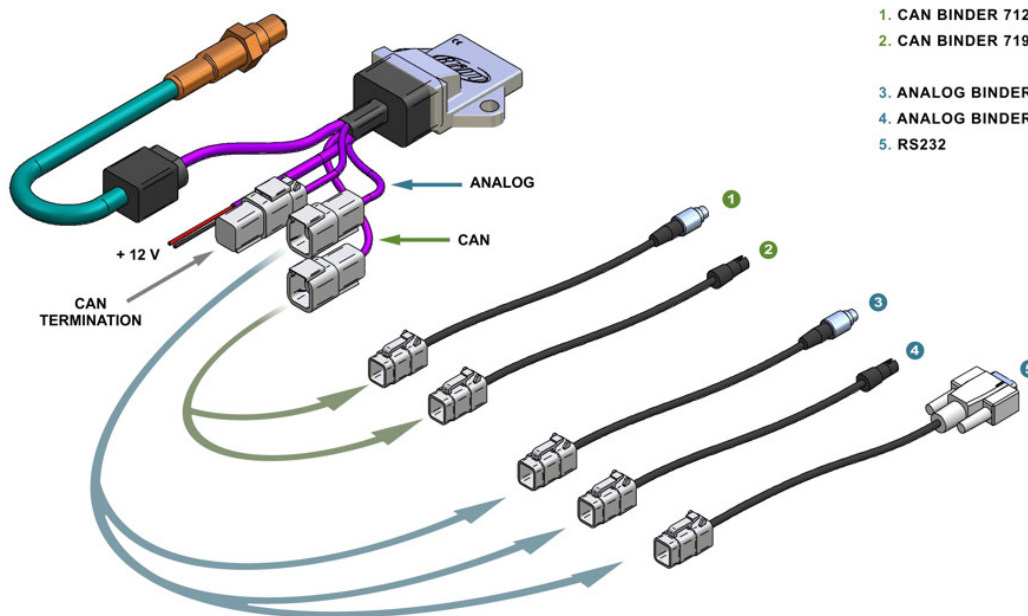

In case of a CAN connection with only one **LCU-ONE**, follow the scheme shown above. Use extensions labelled as “1” and “2” to make CAN connections with AIM loggers that support it. It is reminded to use the proper cap indicated in the figure above (“CAN termination”) to terminate CAN line.

It is suggested to insert a 5 A fuse for each controller in series between external battery and **LCU-ONE** to protect the system.

Refer to this tutorial appendix to know items part number and connectors pinout.

**LCU-ONE, like the logger, needs to be powered by the vehicle master switch.**

As far as the connections with the loggers are concerned refer to each logger user manuals.

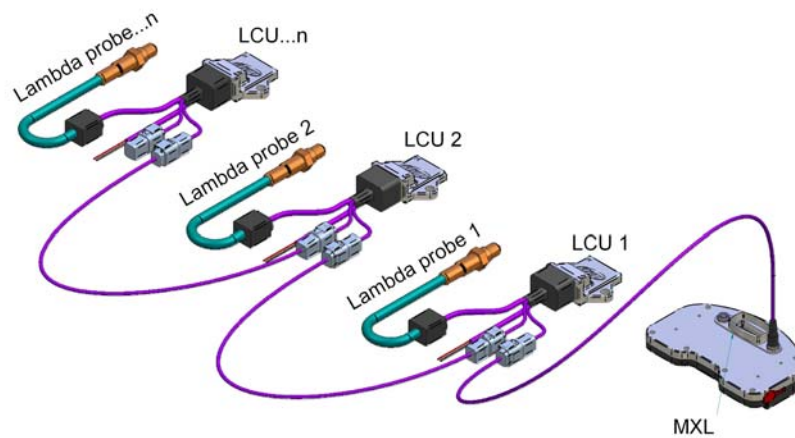

In case of more than one **LCU-ONE**, the scheme to be followed is the one indicated above.

It is suggested to insert a 10 A fuse for each controller in series between the external battery and Lambda controller to protect the system. It is recommended to use the proper cap indicated in the previous figure (“CAN termination”) to terminate the CAN line.

Refer to this tutorial appendix to know each item part number.

**LCU-ONE, like the logger, needs to be powered by the vehicle master switch.**

As far as connections with the loggers are concerned, refer to the related user manuals.

## 6 – LCU-ONE Configuration

To work properly **LCU-ONE** needs to be configured for both the CAN part and the analog part. In case **Race Studio 2** software is available it is possible to use it to completely configure **LCU-ONE**. In case the only analog configuration is needed, follow this instruction.

### 6.1 – LCU-ONE standard analogue configuration

**LCU-ONE** analogue part can be configured both through **Race Studio Configuration** software and using the dedicated **Lambda configurator** software.

Configuration through **Race Studio Configuration** (standard configuration) is only possible if calibration curve points 1.95↔0.65 e 4.8↔1.6 have not been modified.

To use **Race Studio Configurazione** follow this procedure:

run the software;

press “AIM system manager” button on the left vertical keyboard;

select the logger **LCU-ONE** is connected to;

activate channels layer;

select the analogue channel to set the probe on;

double click on type of sensor column corresponding to that channel and select “AIM Lambda LCU-ONE (0.65 – 1.6 Lambda)”, as shown here below and click out of the cell to confirm the choice.

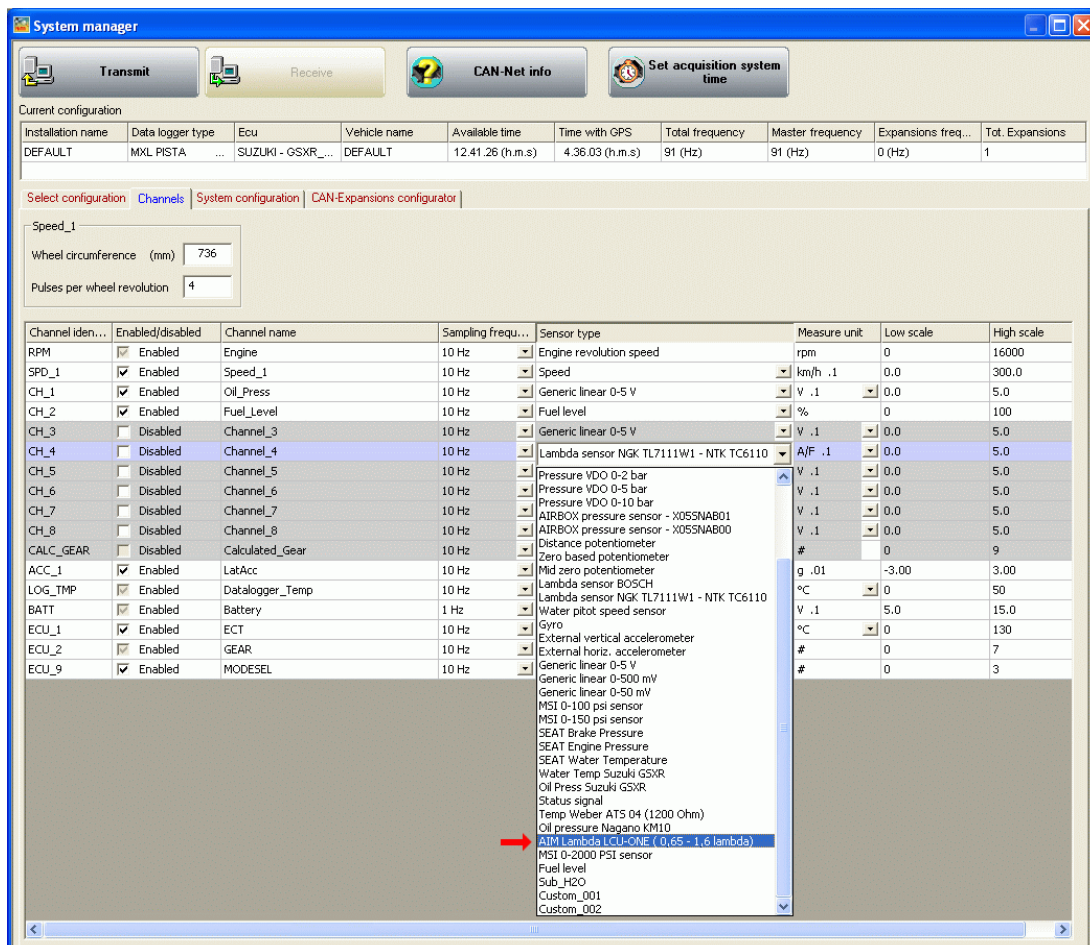

The screenshot shows the 'System manager' window with the 'Channels' tab selected. The 'Current configuration' table at the top shows the system is set to 'DEFAULT' for a 'SUZUKI - GSXR...' vehicle. Below this, the 'Channels' configuration table is visible, with 'Speed\_1' selected. The sensor type dropdown for 'Speed\_1' is open, and 'AIM Lambda LCU-ONE (0,65 - 1,6 lambda)' is highlighted with a red arrow.

Channel iden...	Enabled/disabled	Channel name	Sampling frequ...	Sensor type	Measure unit	Low scale	High scale
RPM	Enabled	Engine	10 Hz	Engine revolution speed	rpm	0	16000
SPD_1	Enabled	Speed_1	10 Hz	Speed	km/h .1	0.0	300.0
CH_1	Enabled	Oil_Press	10 Hz	Generic linear 0-5 V	V .1	0.0	5.0
CH_2	Enabled	Fuel_Level	10 Hz	Fuel level	%	0	100
CH_3	Disabled	Channel_3	10 Hz	Generic linear 0-5 V	V .1	0.0	5.0
CH_4	Disabled	Channel_4	10 Hz	Lambda sensor NGK TL7111W1 - NTK TC6110	A/F .1	0.0	5.0
CH_5	Disabled	Channel_5	10 Hz	Pressure WDO 0-2 bar	V .1	0.0	5.0
CH_6	Disabled	Channel_6	10 Hz	Pressure WDO 0-5 bar	V .1	0.0	5.0
CH_7	Disabled	Channel_7	10 Hz	Pressure WDO 0-10 bar	V .1	0.0	5.0
CH_8	Disabled	Channel_8	10 Hz	AIRBOX pressure sensor - X05SNAB01	V .1	0.0	5.0
CALC_GEAR	Disabled	Calculated_Gear	10 Hz	AIRBOX pressure sensor - X05SNAB00	V .1	0.0	5.0
ACC_1	Enabled	LatAcc	10 Hz	Distance potentiometer	#	0	9
LOG_TMP	Enabled	Datalogger_Temp	10 Hz	Zero based potentiometer	g .01	-3.00	3.00
BATT	Enabled	Battery	1 Hz	Mid zero potentiometer	°C	0	50
ECU_1	Enabled	ECT	10 Hz	Lambda sensor BOSCH	V .1	5.0	15.0
ECU_2	Enabled	GEAR	10 Hz	Lambda sensor NGK TL7111W1 - NTK TC6110	V .1	0.0	5.0
ECU_9	Enabled	MODESEL	10 Hz	Water pitot speed sensor	°C	0	130
				Gyro	#	0	7
				External vertical accelerometer	#	0	3
				External horiz. accelerometer	#	0	3
				Generic linear 0-5 V	#	0	3
				Generic linear 0-500 mV			
				Generic linear 0-50 mV			
				MSI 0-100 psi sensor			
				MSI 0-150 psi sensor			
				SEAT Brake Pressure			
				SEAT Engine Pressure			
				SEAT Water Temperature			
				Water Temp Suzuki GSXR			
				Oil Pres Suzuki GSXR			
				Status signal			
				Temp Weiber ATS 04 (1200 Ohm)			
				Oil pressure Nagano KM10			
				AIM Lambda LCU-ONE (0,65 - 1,6 lambda)			
				MSI 0-2000 PSI sensor			
				Fuel level			
				Sub_H2O			
				Custom_001			
				Custom_002			

Set the probe configuration panel that appears bottom on the left of channel layer, highlighted in the figure here below.

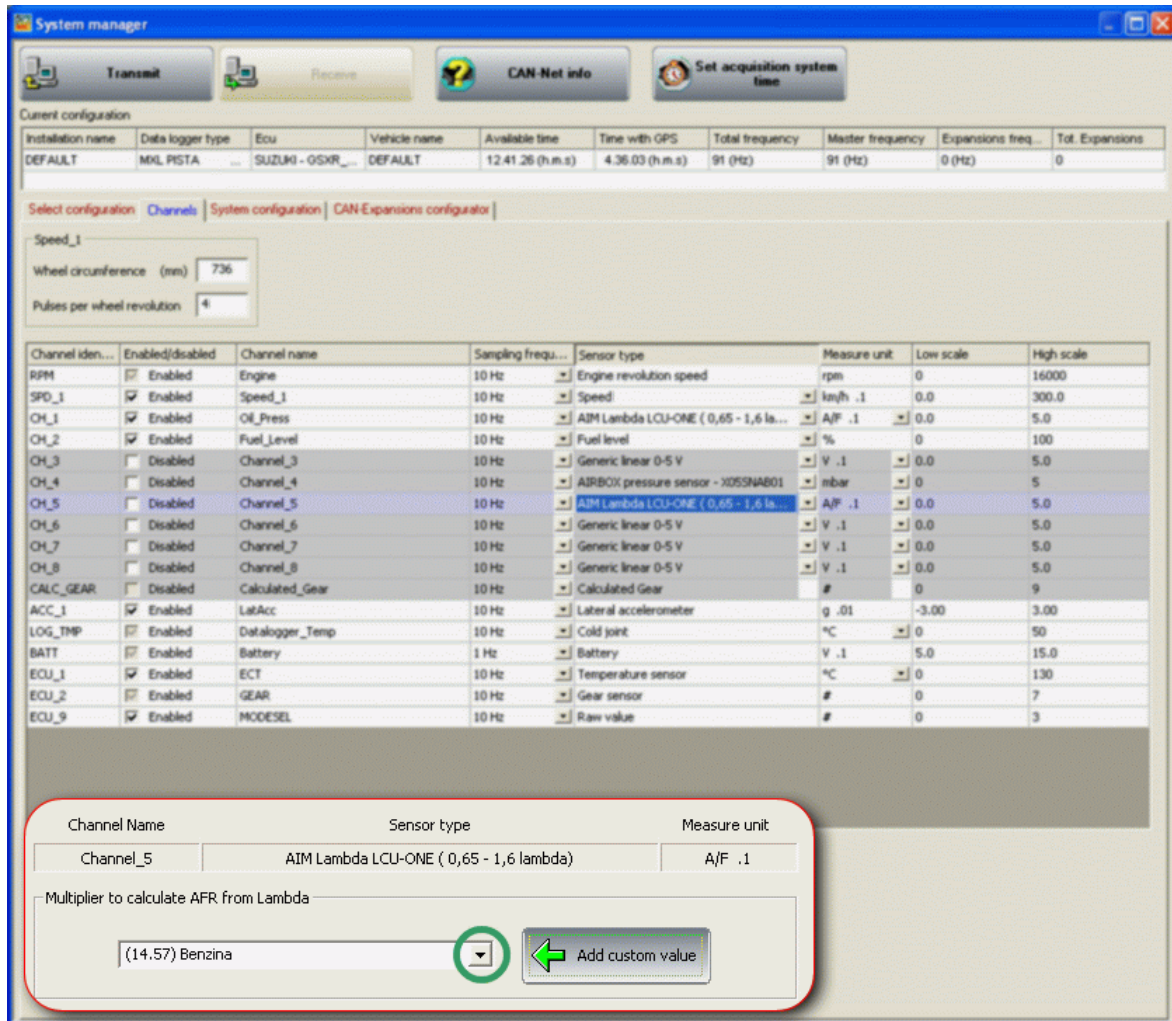

Activate the drop down menu pressing the button green circled in the figure here above and select the type of fuel used by the vehicle.

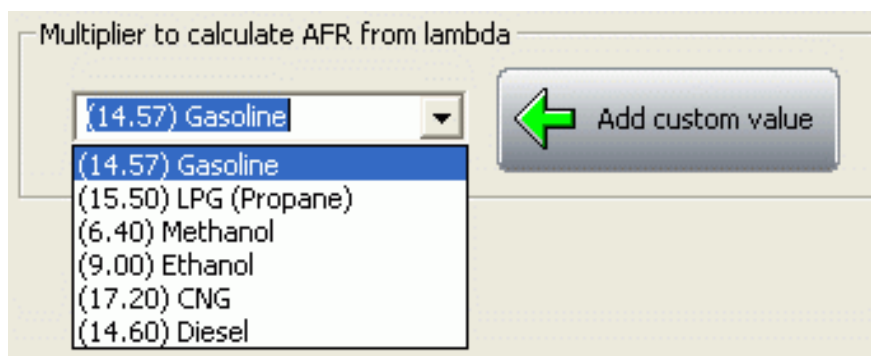

In case the used fuel is not included in the database (and **only in case its Stoichiometric value is known**) press “Add custom value” button and the window here below appears.

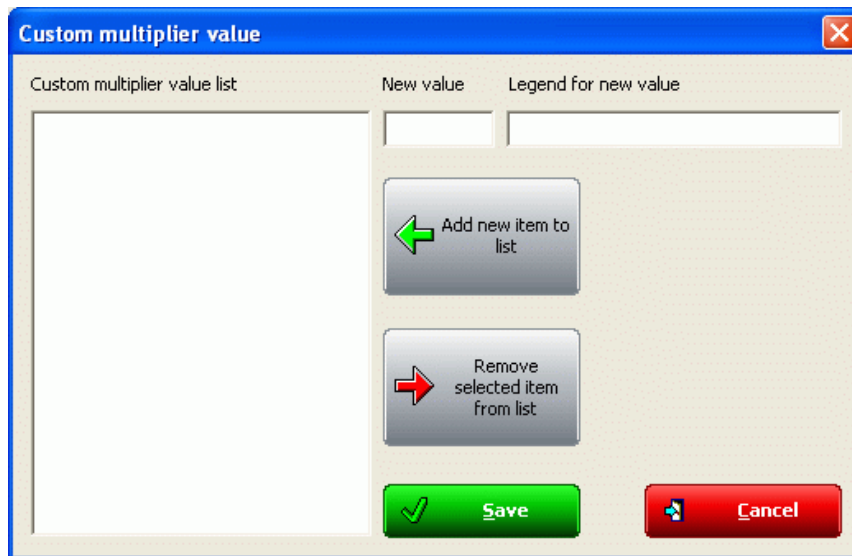

Fill in the new value and its legend. Press “Add new item to” button and then “Save” button.

The fuel is now available in the drop down menu: select it.

## 6.2 – LCU-ONE Analog custom configuration

In case calibration curve default points have been changed it is necessary to configure **LCU-ONE** analog part using **Lambda Configurator**, the software properly designed and developed by AIM to manage this device and freely downloadable from AIM website [www.aim-sportline.com](http://www.aim-sportline.com).

**Warning: to correctly configure the controller, ensure that Lambda Configurator is 1.00.07 or later. Moreover it is suggested to perform this operation with the controller switched on and connected.**

To configure **LCU-ONE Analog** run the software. The window below appears.

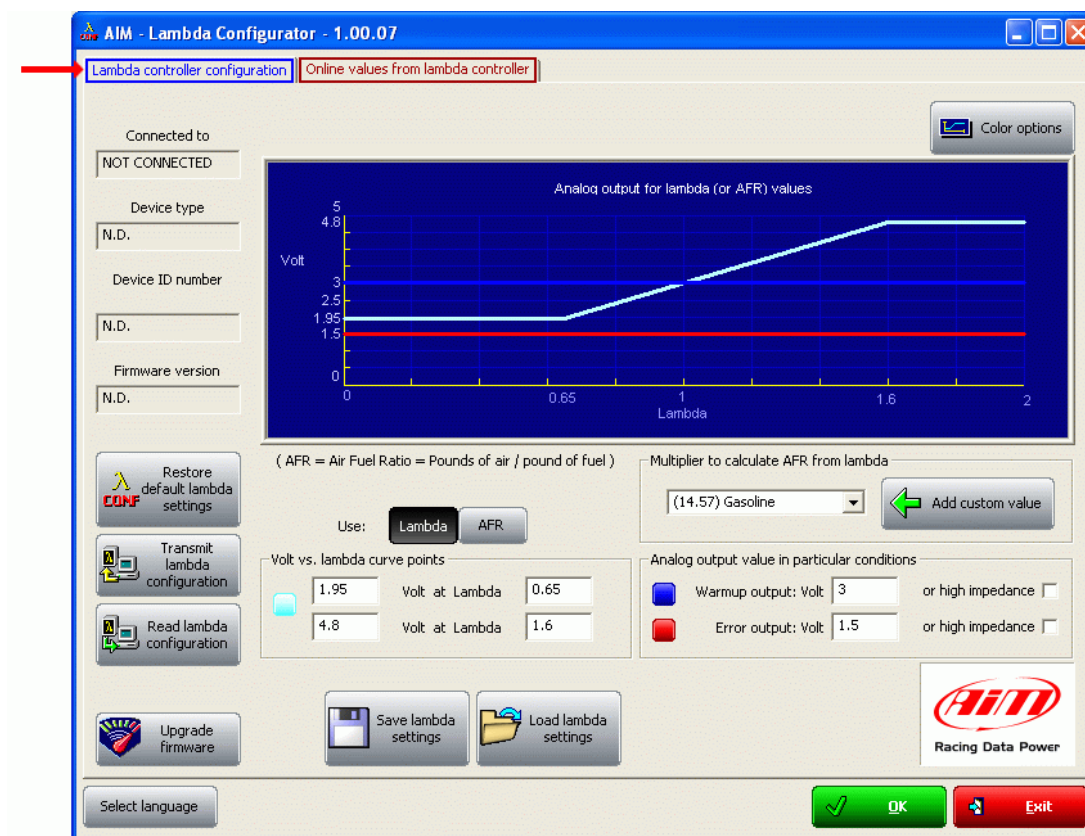

This is the software main window, made of two layers:

- **Lambda controller configuration**: shows analog output for lambda (or AFR) values graph (central) and is used to configure **LCU-ONE Analog**, read and transmit the configuration, restore default lambda settings and upgrade **LCU-ONE** firmware (see paragraph concerning preliminary operations).
- **Online values from Lambda controller**: shows the status of the connection between **LCU-ONE** and the PC.

### 6.2.1 – Preliminary operation

**Lambda Configurator** software, differently from other AIM software, includes a firmware version of the logger it configures. This is why it is suggested to always check [www.aim-sportline.com](http://www.aim-sportline.com) to know if the software version installed on the PC is the last available. If not download the last one, install it and follow this procedure:

- connect **LCU-ONE** to the PC serial port
- read logger firmware version that appears in the proper case on the left of the central graph
- press “**Upgrade firmware**” button
- this panel appears:

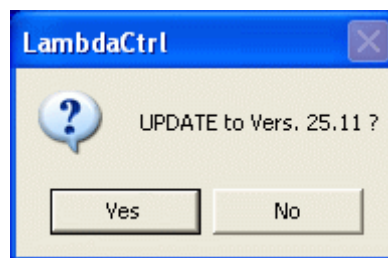

If firmware version proposed (in the image above the software proposes version 25.11) is more recent than the one installed on the controller (if for instance the logger has a version 25.08) press “Yes” button and upgrade the firmware.

### 6.2.2 – Lambda controller Configuration

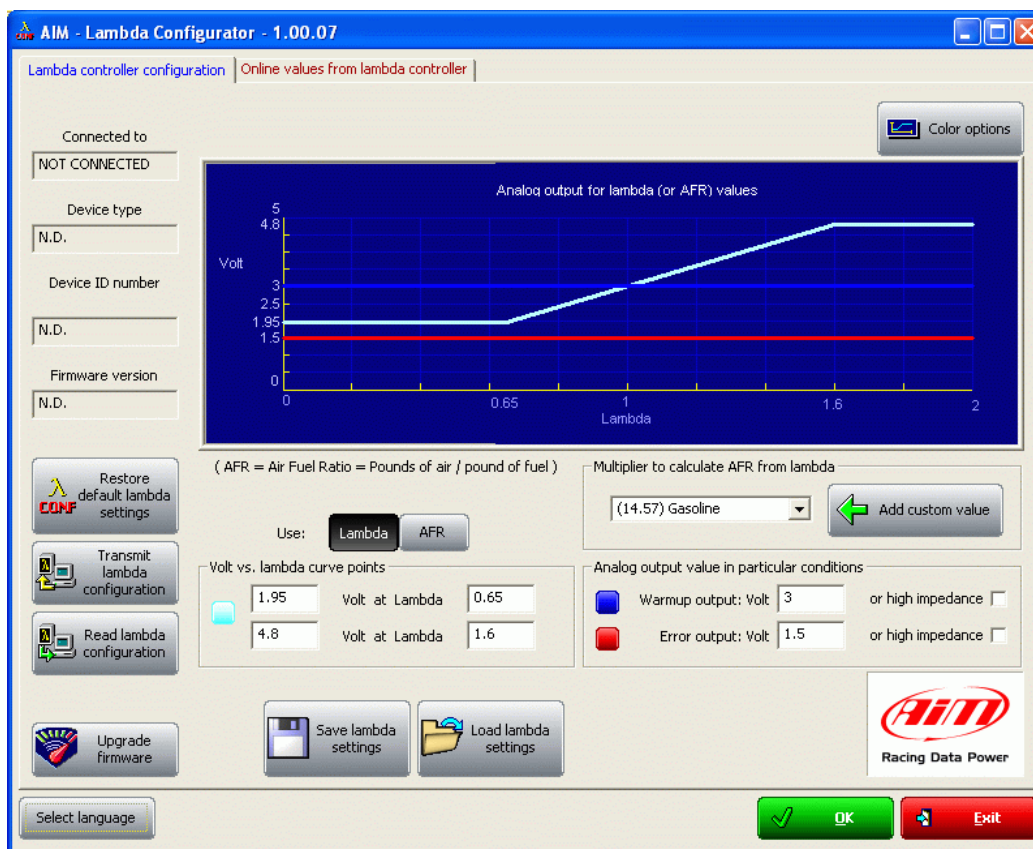

Under the central graph are configuration panels.

( AFR = Air Fuel Ratio = Pounds of air / pound of fuel )

Use: **Lambda** AFR

Volt vs. lambda curve points

<input type="checkbox"/>	1.95	Volt at Lambda	0.65
<input type="checkbox"/>	4.8	Volt at Lambda	1.6

Multiplier to calculate AFR from lambda

(14.57) Gasoline

Analog output value in particular conditions

Warmup output: Volt 3 or high impedance

Error output: Volt 1.5 or high impedance

The first operation to perform is selecting the used fuel in the pop up menu of **“Multiplier to calculate AFR from Lambda”** panel shown below or insert a new multiplier following the procedure here explained.

Multiplier to calculate AFR from lambda

(14.57) Gasoline

- (14.57) Gasoline
- (15.50) LPG (Propane)
- (6.40) Methanol
- (9.00) Ethanol
- (17.20) CNG
- (14.60) Diesel

In case the used fuel is not included in the database (and **only in case its Stoichiometric value is known**) press “Add custom value” button and the window shown below appears.

**Custom multiplier value**

Custom multiplier value list	New value	Legend for new value
	<input type="text"/>	<input type="text"/>

Insert the new value and the related legend. Press “Add new item to list” button and then “Save” button.

Likewise, selecting a multiplier from the left box labelled “Custom multiplier value list” and pressing “Remove selected item from list”, a multiplier is removed.

Afterwards operate on the other parameters.

( AFR = Air Fuel Ratio = Pounds of air / pound of fuel )

Use:

Multipier to calculate AFR from lambda

Volt vs. lambda curve points

<input type="checkbox"/>	<input type="text" value="1.95"/>	Volt at AFR	<input type="text" value="9.47"/>
<input type="checkbox"/>	<input type="text" value="4.8"/>	Volt at AFR	<input type="text" value="23.31"/>

Analog output value in particular conditions

Warmup output: Volt  or high impedance

Error output: Volt  or high impedance

“Use: Lambda/AFR” these buttons allow the user to decide if showing Lambda values or AFR (Stoichiometric values). This choice reflects on the layout of the panel, as shown below:

Volt vs. lambda curve points			
<input type="checkbox"/>	<input type="text" value="1.95"/>	<input type="text" value="Volt at Lambda"/>	<input type="text" value="0.65"/>
<input type="checkbox"/>	<input type="text" value="4.8"/>	<input type="text" value="Volt at Lambda"/>	<input type="text" value="1.6"/>

Volt vs. lambda curve points			
<input type="checkbox"/>	<input type="text" value="1.95"/>	<input type="text" value="Volt at AFR"/>	<input type="text" value="9.47"/>
<input type="checkbox"/>	<input type="text" value="4.8"/>	<input type="text" value="Volt at AFR"/>	<input type="text" value="23.31"/>

The coloured button beside the cases indicates the colour this value is drawn in the central graph (in the example the value is shown in light blue).

When the values to show have been decided it is sufficient to fill in the cases with the desired values or leave default ones.

When all values have been inserted it is necessary to transmit the configuration to **LCU-ONE** pressing “Transmit Lambda configuration” button in the left lateral keyboard.

The system shows a confirm message or an error message in case PC connection is not OK (right figure).

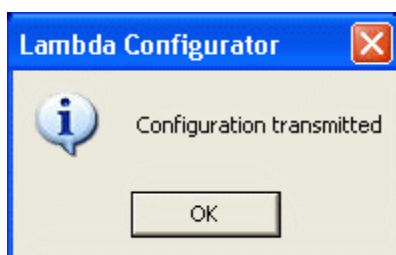

### 6.2.3 – The keyboard

On the left of the window are some buttons:

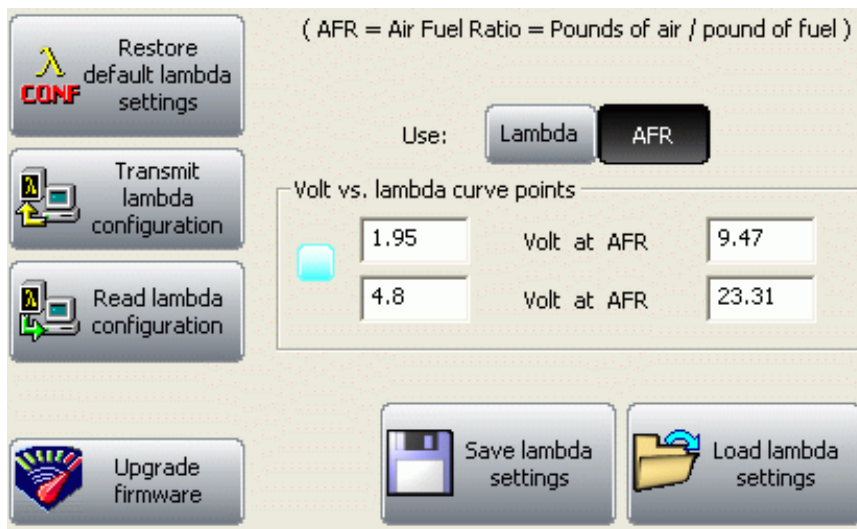

- “Restore default lambda settings”: allows the user to restore default settings on **LCU-ONE**.
- “Transmit lambda configuration”: allows the user to transmit the configuration to the device
- “Read lambda configuration”: reads the configuration from a logger
- “Upgrade Firmware”: allows the user to update controller firmware.

Bottom central are these buttons:

- “Save lambda settings”: allows the user to export a lambda configuration
- “Load lambda settings”: allows the user to import a Lambda configuration and transmit it to the controller

In the lower part of the window are:

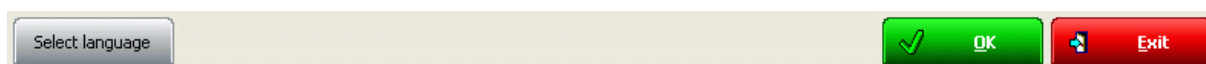

- on the left “*Select language*”: allows to change the software language
- on the right “OK” button to save fixed settings and “Exit” to quit without saving.

### 6.2.4 – Informative panels

Top left of the software main window, a series of panels shows some information concerning the connected **LCU-ONE**. These panels layout changes depending on the fact that the logger is connected or not.

The figure below shows panels layout with **LCU-ONE** connected on the left and with the controller not connected on the right.

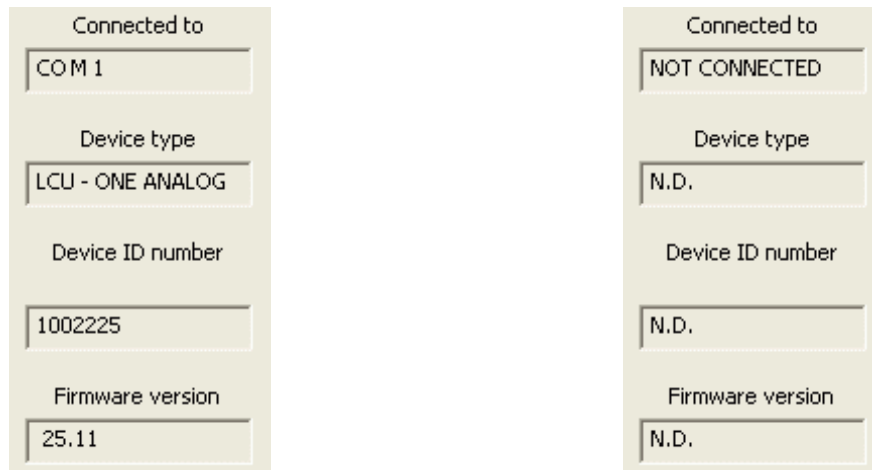

- Connected to: PC serial port
- Device type: LCU-ONE Analog (the controller has been recognised)
- Device ID number: controller unique ID number
- Firmware Version: controller firmware version.
- If **LCU-ONE** is not connected; the panel shows the message “not connected” and all data concerning the controller are set on N.D. (Not available)

### 6.2.5 – The analog output graph

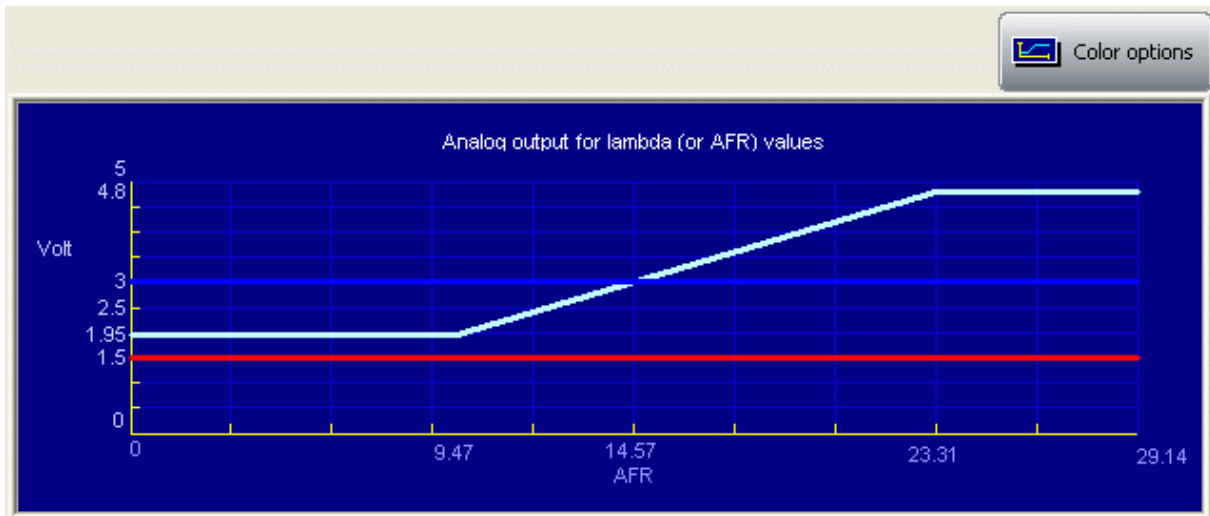

The “analog output graph” shows output tension values of the controller that refer to measured Lambda (or AFR) values. Graph colours can be changed. Pressing “Colour options” button top on the right and this window appears:

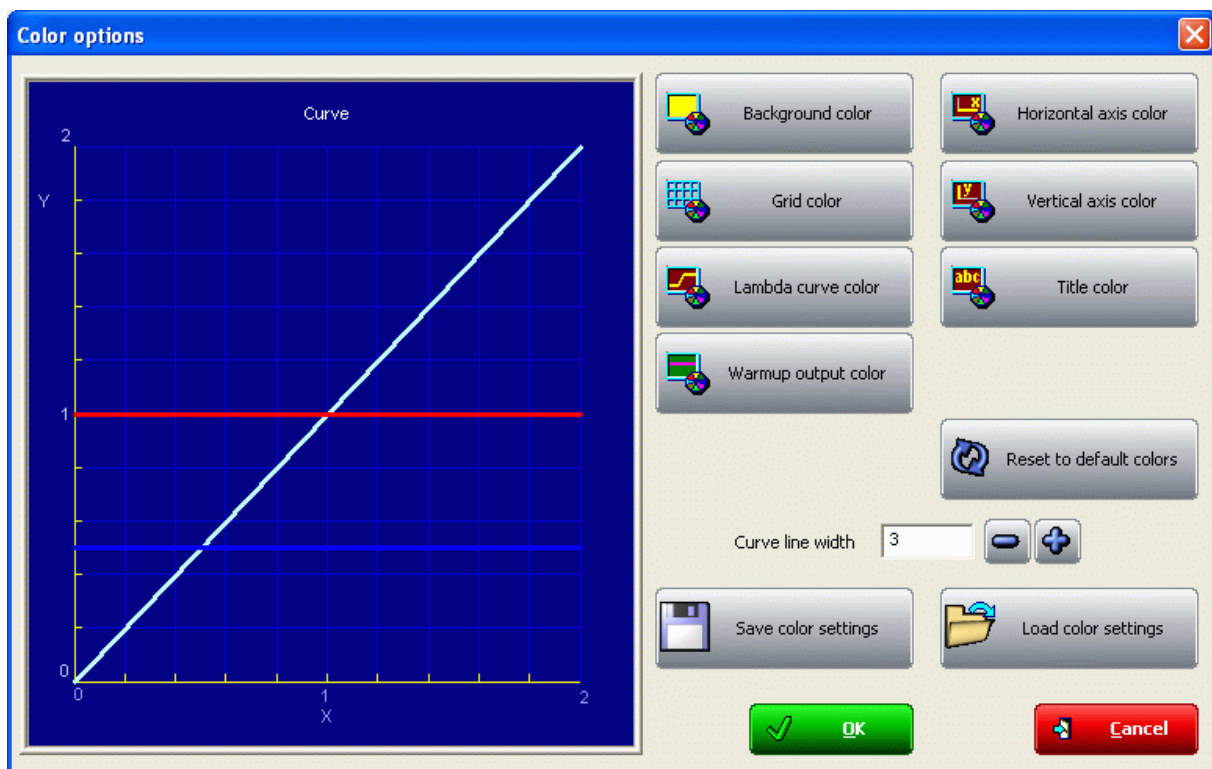

Pressing each button a colour choice panel appears showing the available colours for that graph characteristic. Selecting the desired colour and confirming the choice the graph layout changes.

### 6.2.6 – Online values from Lambda controller.

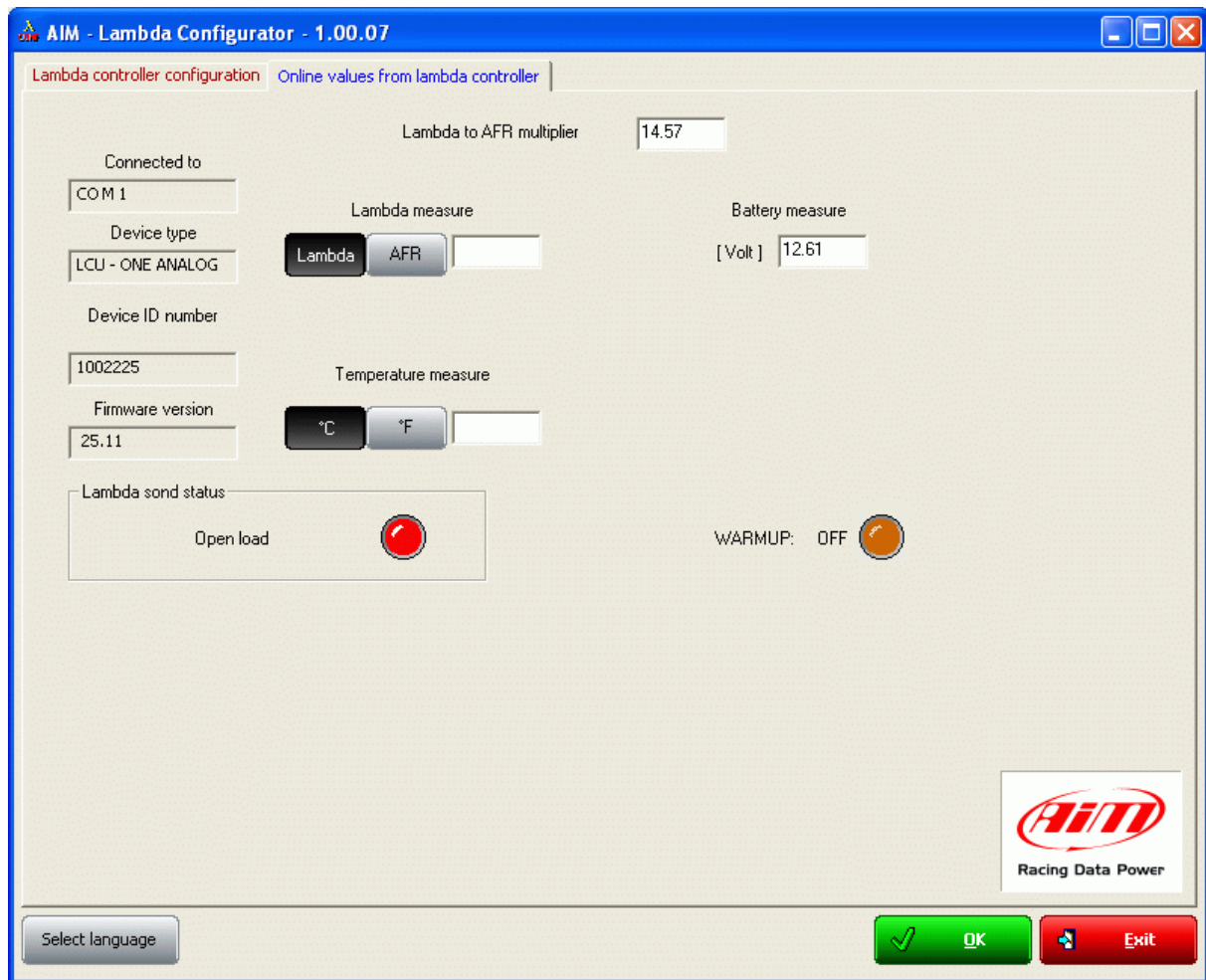

This panel shows the controller status and allows the user to set only Lambda/AFR and temperature unit of measure for the shown values.

### 6.3 – LCU-ONE CAN configuration

As said before, **LCU-ONE** can communicate using the CAN bus too and this type of communication allows it to interface with AIM **MXL/EVO3**. To better profit by this channel it is necessary to configure the controller with **Race Studio 2** software. Refer to the related user manual for further information on the software and to the loggers user manual for further information on these latter and their configuration.

It is suggested to perform this operation with the logger and the controller switched on and connected. Run the software and select the desired logger: **MXL** or **EVO3 PRO/Pista**. The window below appears. Select “**CAN-Expansions configurator**” layer. In case of very first configuration the layer is empty as shown below.

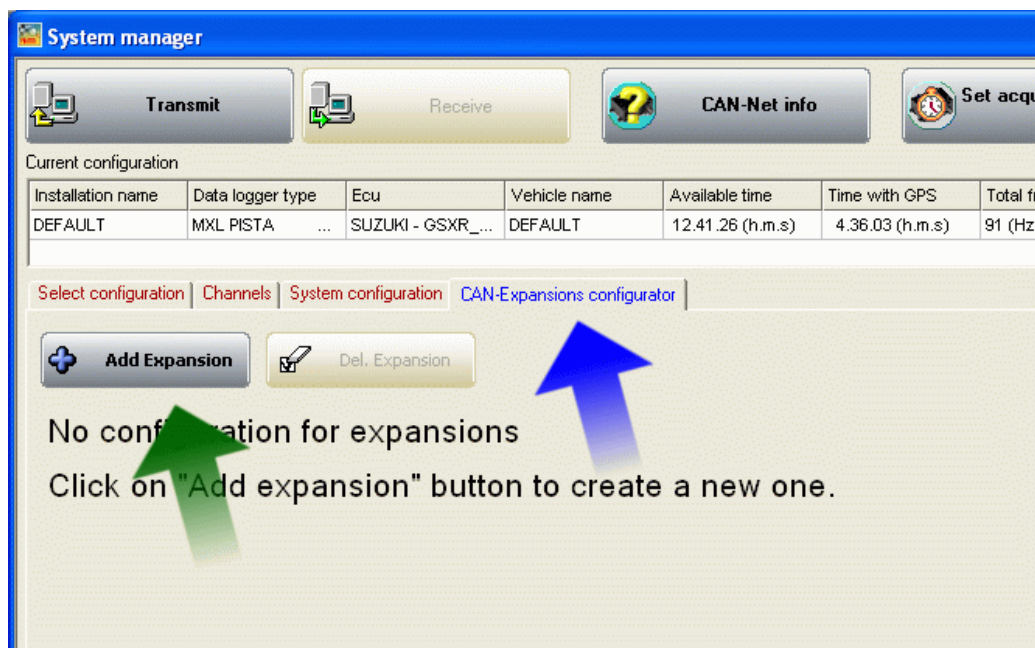

Press “Add Expansion” button and the window shown below appears:



Select **LCU-ONE CAN (CAN only or CAN+analog output)**. The two fields under the keyboard enables, press “*Get serial number from a connected expansion button*” and the system reads the controller serial number. It is also possible to insert this information manually keeping it from the controller.

**Repeat this operation as many times as many lambda probes are connected.**

The layer is modified as shown below and as many additional layers as many Lambda probe have been added appear.

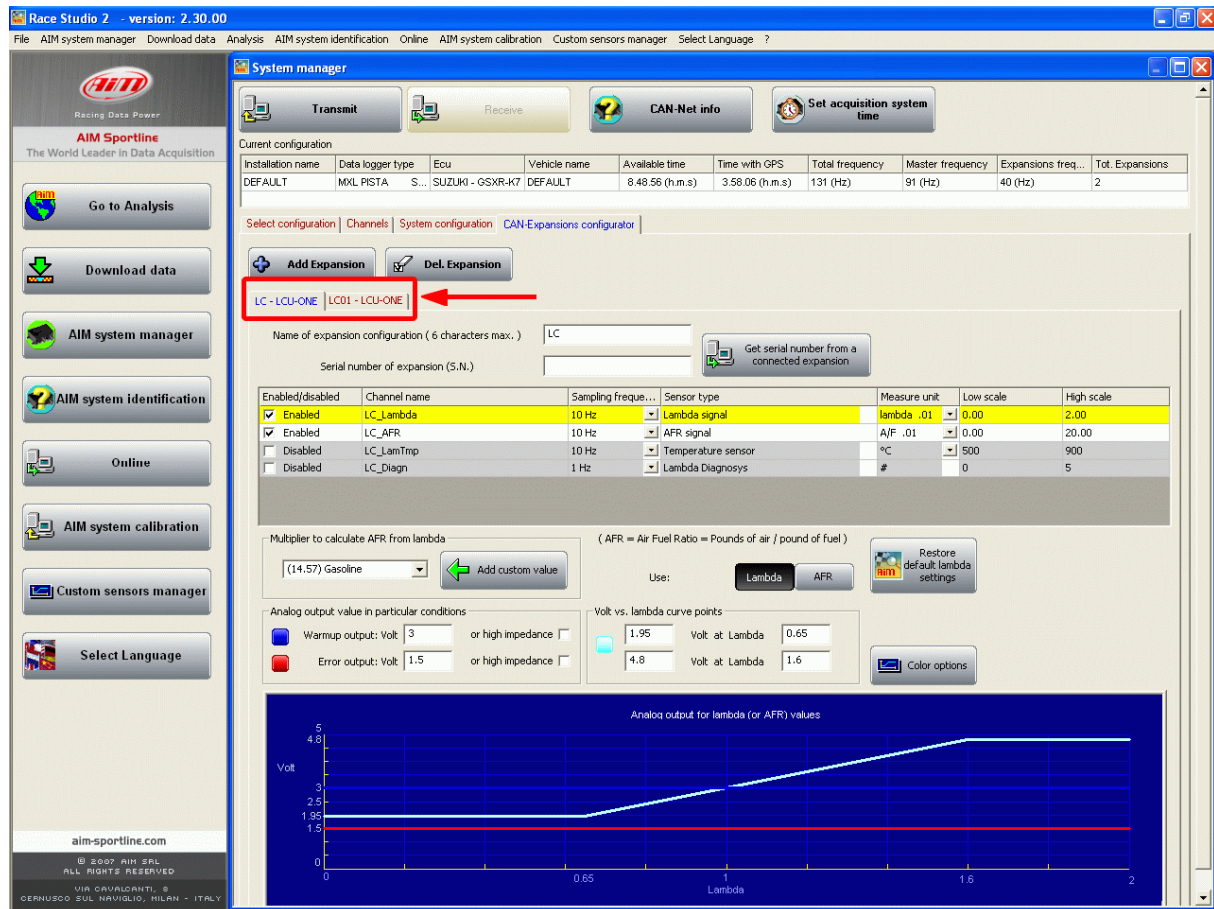

In case serial number has not been get, press “Get serial number from a connected expansion” button.

**Warning: this operation is necessary to transmit the configuration to the controller.**

The layer concerning the probe is shown above.

**Top**

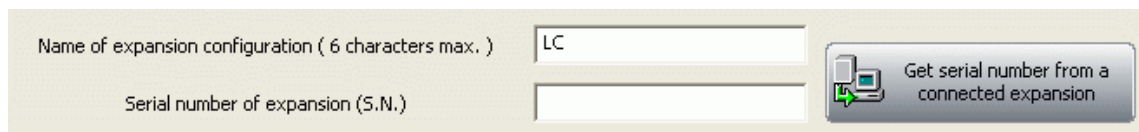

Fields “Name of expansion configuration (6 characters max)” and “Serial number of expansion”. Inserting a name for the new configuration the layer label is modified live. As far as serial number is concerned, see before.

Central in the page a table made of 7 columns shows the controller channels.

Enabled/disabled	Channel name	Sampling freque...	Sensor type	Measure unit	Low scale	High scale
<input checked="" type="checkbox"/> Enabled	LC_Lambda	10 Hz	Lambda signal	lambda .01	0.00	2.00
<input checked="" type="checkbox"/> Enabled	LC_AFR	10 Hz	AFR signal	A/F .01	0.00	20.00
<input type="checkbox"/> Disabled	LC_LamTmp	10 Hz	Temperature sensor	°C	500	900
<input type="checkbox"/> Disabled	LC_Diagn	1 Hz	Lambda Diagnosys	#	0	5

Enabled/disabled: shows channel status (enabled/disabled). It can be modified checking or un-checking the related checkbox. LCC\_lambda (Lambda value) and LCC\_AFR (AFR value) channels are enabled by default.

Channel name: shows the name of the channel and can be modified double clicking on the cell, that becomes editable.

Sampling Frequency: shows the channel sampling frequency and can be set through the pop up menu that appears clicking on the cell (accepted values are from 1 to 50 Hz).

Sensor type: shows the sensor installed on that channel and can not be modified.

Measure Unit: shows the unit of measure used to sample that channel and can be modified double clicking on the cell.

Low/High scale: these columns show the channels low and high scale and can be modified double clicking on the cells.

**Under** the table is “Multiplier to calculate AFR from lambda” field. It allows to both change used fuel and insert a new one.

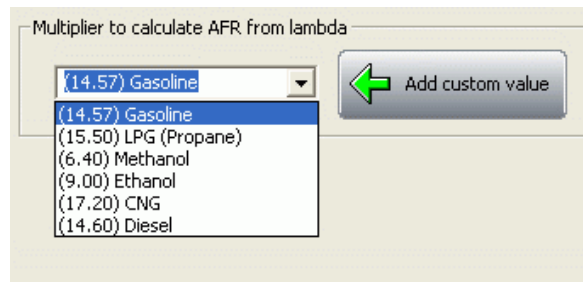

Select the used fuel to show AFR.

In case used fuel is not included in the database and **only in case its Stoichiometric value is known** press “Add custom value” button and the figure below appears.

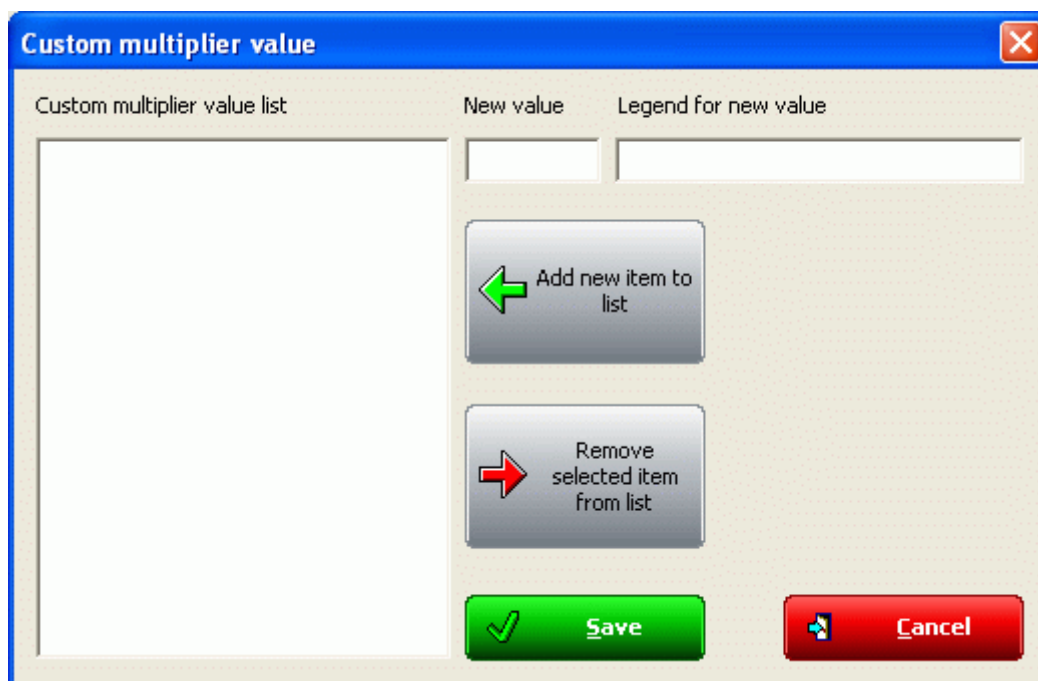

Insert the new value and the related legend. Press “Add new item to list” button and then “Save” button.

Likewise, selecting a multiplier from the left box labelled “Custom multiplier list” and pressing “Remove selected item from list” button the multiplier is removed.

The **remaining part of the layer** refers to the configuration of **LCU-ONE** analog part. This part of **Race Studio 2** works like **Lambda Configurator**. Refer to the related paragraph for the analog configuration.

Once enabled/disabled the channels it is possible to decide which channel to show on the display depending on the logger and on the connected peripherals. In case of an **MXL** it is possible to show the channels setting them in “System configuration” layer.

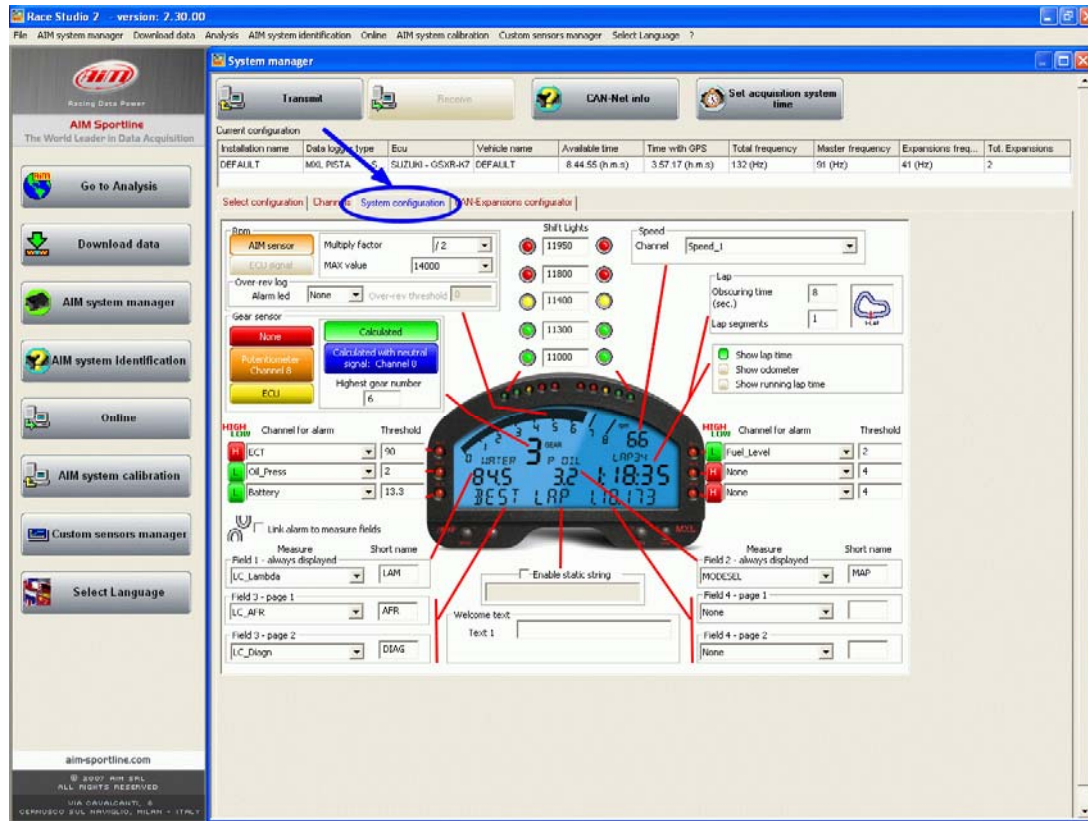

In this example enabled channels are LCC\_Lambda, LCC\_AFR and LCC\_diagnosis. As shown below each channel can be set in a display field. The example shows the channels set on the fields of pages 1 and 2 of **MXL** (blue box).

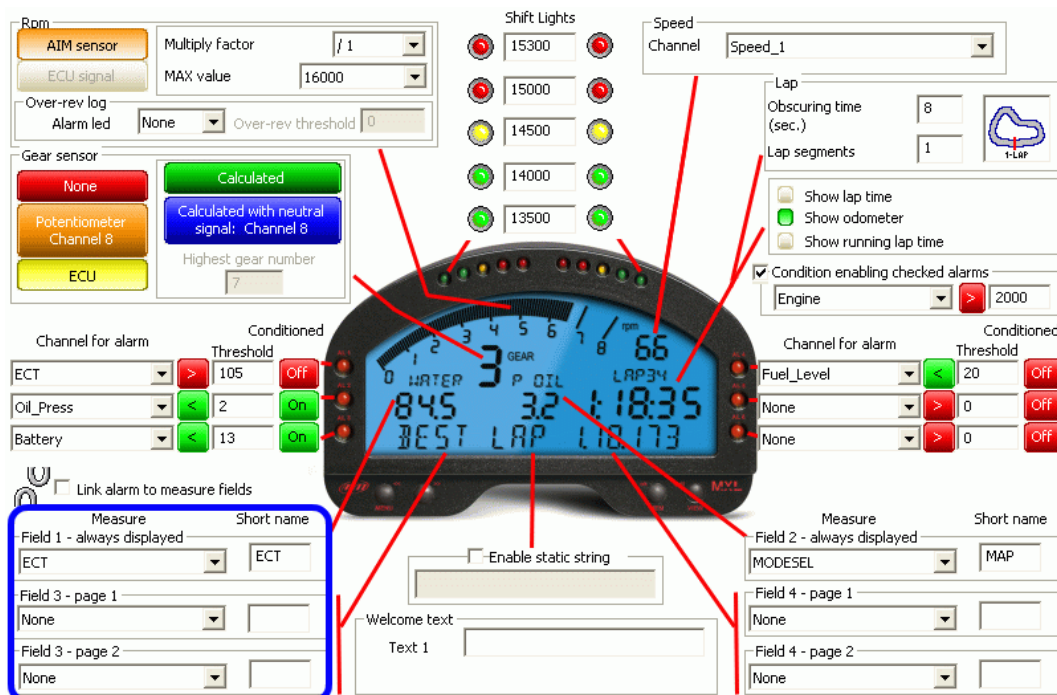

In case of an **EVO3** data visualisation is only possible if the logger is connected to a **Formula Steering Wheel** or to a **MyChron3 Dash** and they are set on that display configuration as shown below.

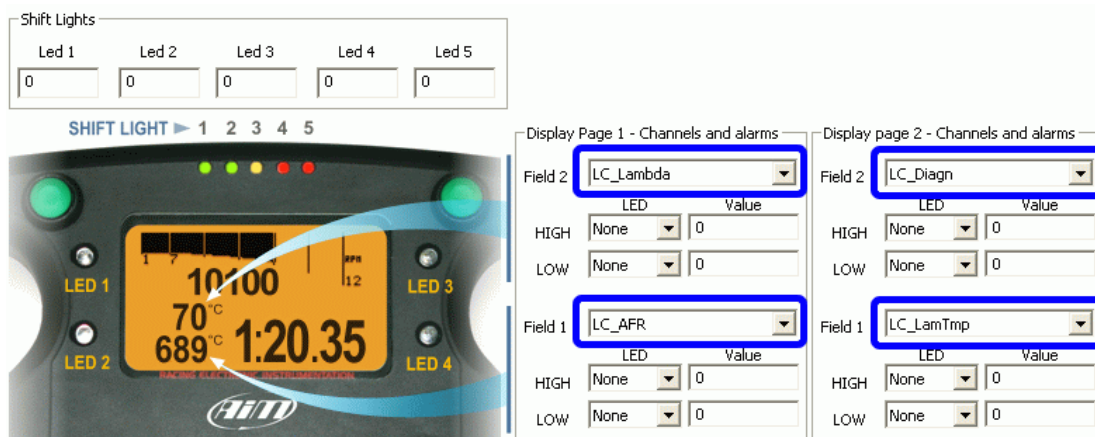

**Note:** **LCC\_diagnosis channel** shows the probe working status and can show up to four messages:

- 0: status OK
- 1: probe not connected
- 2: + 12 V short circuit
- 3: GND short circuit

The configuration is now ready to be transmitted to the logger.

**Warning:** this operation needs to be repeated for all the connected LCU-ONE.

When all parameters have been set and the fields assigned it is necessary to transmit the configuration to the logger pressing “*Transmit*” button on **Race Studio 2** top keyboard.

If the configuration has been correctly transmitted the system shows no messages. Otherwise, the system shows the window below.

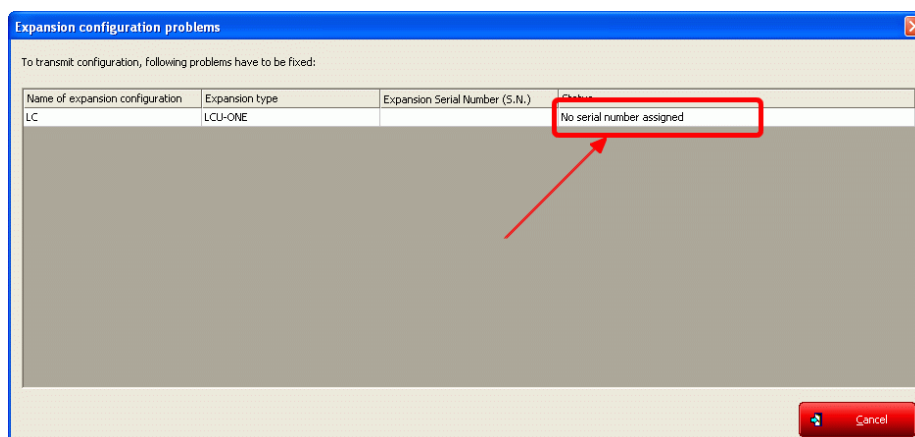

It warns the user that no serial number has been assigned to the connected expansion. It is thereby necessary to close this window pressing “*Cancel*” button and get the expansion serial number pressing “*Get serial number form a connected expansion*” button as explained before.

## 7 – Data visualisation on MXL/EVO3

### 7.1 – Data visualisation on MXL

The visualisation of Lambda channels on **MXL** works like the visualisation of any other channel and switch from one page to the other of the display is made through “MEM/View” button. Refer to **MXL** user manual for further information. In the image below Lambda value is **0.955** and channel name is **LAM**.



Switching **MXL** on, Lambda controller is recognised at start up and probe warm-up procedure starts. During this period the controller takes the probe to its working temperature (up to around 780 °C – 1436 °F). During warm-up (around 20-30 seconds), Lambda value shown on the display is 1.00. When the probe is 100% working displayed value becomes, with the engine off, 1.60 (free air).

**Warning:** it is reminded that **LCU-ONE**, like the logger, needs to be powered by the vehicle master switch.

### 7.2 – Data visualisation on EVO3

Visualisation of lambda channels on **EVO3** works exactly like the visualisation of any other channel and is possible only if the logger is connected to a display like **MyChron3 Dash** and **Formula Steering wheel**. Refer to **EVO3** user manual for further information. In the image below Lambda value is 0.95 and the field is labelled as “λ”



Switching **EVO3** on, Lambda controller is recognised at start up and probe warm-up procedure starts. During this period the controller takes the probe to its working temperature (until around 780 °C – 1436 °F). During warm-up (around 20-30 seconds), lambda value shown on the display is 1.00. When the probe is 100% working, that value becomes, with the engine off, 1.60 (free air).

**Warning:** it is reminded that **LCU-ONE** needs to be powered, like the logger, by the vehicle master switch.

## 8 – Data analysis with Race Studio Analysis

During data analysis, the presence of Lambda controller adds one or more channels, depending on which channels have been enabled in **LCU-ONE** layer, to measures toolbar (as shown in the figure below):

**Lambda:** shows Lambda value recorded during the session;

**Lambda\_Temp:** indicates the probe internal temperature while working;

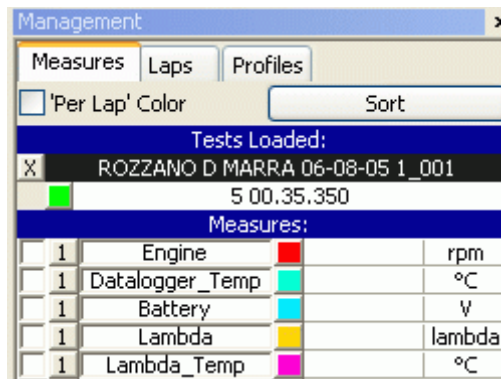

To better analyse engine carburation values, it is suggested to show XY Lambda graph with RPM value on abscissa value and Lambda value on ordinate axle.

This way a more immediate reading of carburetion status is available.

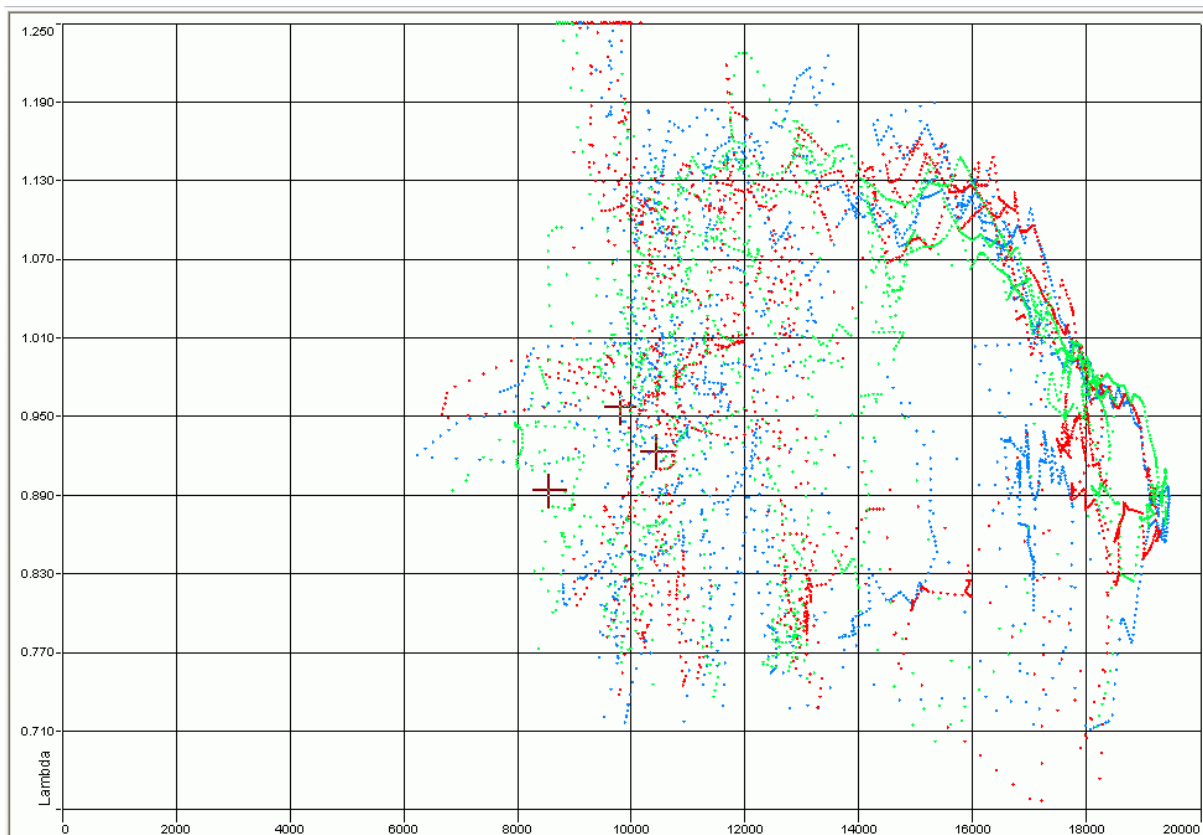

## Appendix – Part numbers and technical drawings

### “A” – Part number of LCU-ONE CAN+Analog complete kit

**WARNING: each kit contains one only extension for each communication protocol and depending on the connector (plastic or metallic) that is wished on the wiring and that is in any case included in the kit, kit part number is going to change following this table.**

**LCU-ONE CAN+Analog** complete kit includes:

LCU-ONE CAN+Analog	
Bosch LSU 4.9 lambda probe	
CAN+Analog + RS232 wiring	X08LCKACR
Extension with plastic RS232 Deutsch connector	
CAN line termination cap	
Metallic CAN + metallic Analog	X08LCKACR710
Plastic CAN + metallic Analog	X08LCKACR711
Metallic CAN + plastic Analog	X08LCKACR610
Plastic CAN + plastic Analog	X08LCKACR611

### “B” – Spare parts

BOSCH LSU 4.9 Lambda probe	X05LSU490
CAN + Analog + RS232 wiring	V02359040
Analog extension plastic Deutsch Binder 712 (metallic)	V02359070
Analog extension plastic Deutsch Binder 719 (plastic)	V02359060
Extension plastic RS232 Deutsch connector	V02539130
CAN extension plastic Deutsch Binder 712 (metallic)	V02359100
CAN extension plastic Deutsch Binder 719 (plastic)	V02359110
CAN termination cap	V02359080

**“B” – Technical drawings**

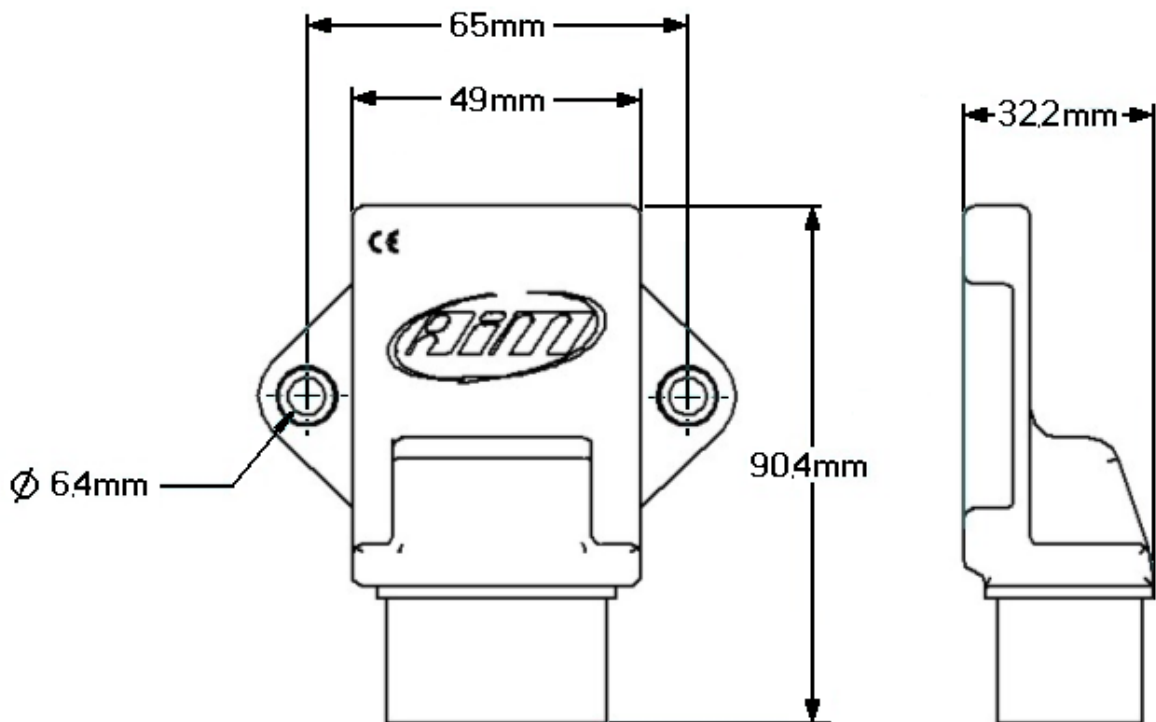
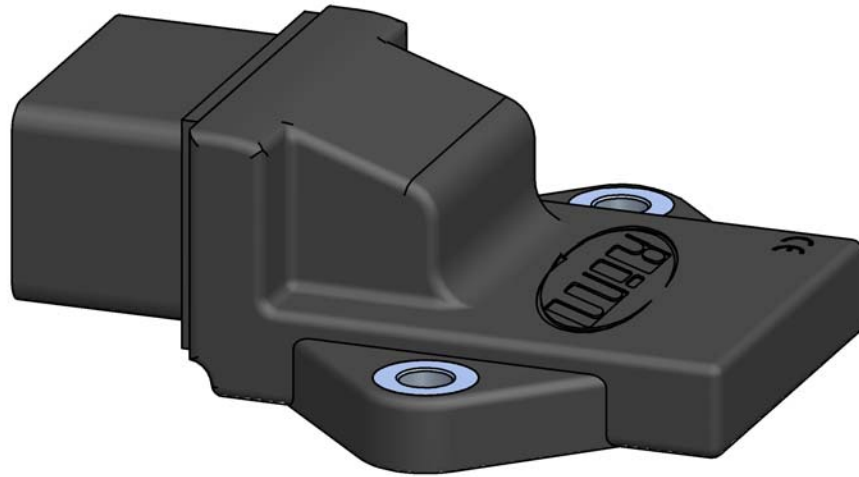



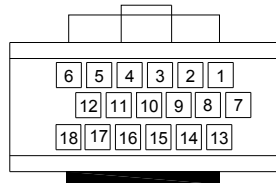
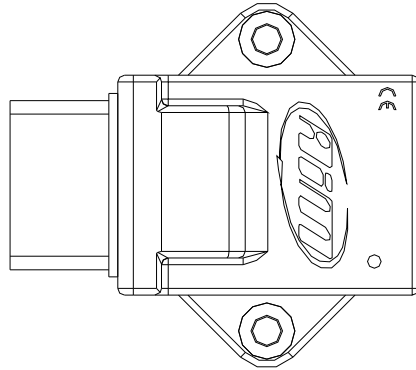

N.rev. / Rev. N.	Descrizione / Description	Data / date	Firma / Sign	Contr. da / Ckd. by
------------------	---------------------------	-------------	--------------	---------------------



## PINOUT LCU-ONE CAN+Analog

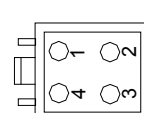
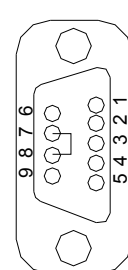

16 pin AMP male connector pinout			
1	GND (power)	10	Rcal
2	+V batt	11	IP+
3	H-	12	RS232TX PC
4	IP-/VS-	13	CAN+
5	VS+	14	CAN-
6	RS232RX PC	15	nc
7	+VB	16	GND (signal)
8	GND (CAN)	17	Lambda Out
9	H+	18	GND (RS232)

Rif. / Ref.	Q.tà / Q.ty	Materiale / Material		N. articolo / Item N.	
Progettato da / Designed by L.I.	Contr. da / Ckd. by	Approvato da / Approved by	Nome file / File name		Data / Date
		Titolo / Title Pinout LCU-ONE CAN+Analog			
		N. disegno / Drawing N.		Rev. / Rev.	Foglio / Sheet <b>1 di 1</b>

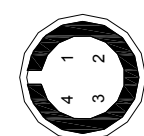
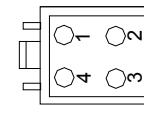
N.rev. / Rev. N.		Descrizione / Description		Data / date	Firma / Sign	Contr. da / Ckd. by																				
<h2 style="margin: 0;">RS232 programming cable via Analog for LCU-ONE CAN+Analog</h2>																										
																										
<p style="text-align: center;">Connettore Deutsch 4 pin femmina</p>																										
<p style="text-align: center;">9 pins DB9 serial female connector</p>																										
<p><b>NOTE:</b> for the serial line to work properly make a connection between pins 7 (RTS) and 8 (CTS) of DB9 connector</p>																										
																										
<p style="text-align: center;">4 pins Deutsch female connector pinout Contacts insertion view</p>																										
																										
<p style="text-align: center;">9 pins serial DB9 female connector pinout Contacts insertion view</p>																										
<table border="1" style="width: 100%; border-collapse: collapse;"> <thead> <tr> <th style="width: 15%;">Deutsch connector pinout</th> <th></th> </tr> </thead> <tbody> <tr><td>1</td><td>nc</td></tr> <tr><td>2</td><td>GND</td></tr> <tr><td>3</td><td>RS232RX PC</td></tr> <tr><td>4</td><td>RS232TX PC</td></tr> </tbody> </table>							Deutsch connector pinout		1	nc	2	GND	3	RS232RX PC	4	RS232TX PC										
Deutsch connector pinout																										
1	nc																									
2	GND																									
3	RS232RX PC																									
4	RS232TX PC																									
<table border="1" style="width: 100%; border-collapse: collapse;"> <thead> <tr> <th style="width: 15%;">DB9 connector pinout</th> <th></th> </tr> </thead> <tbody> <tr><td>1</td><td>nc</td></tr> <tr><td>2</td><td>RS232RX PC</td></tr> <tr><td>3</td><td>RS232TX PC</td></tr> <tr><td>4</td><td>NC</td></tr> <tr><td>5</td><td>GND</td></tr> <tr><td>6</td><td>nc</td></tr> <tr><td>7</td><td>nc</td></tr> <tr><td>8</td><td>nc</td></tr> <tr><td>9</td><td>nc</td></tr> </tbody> </table>							DB9 connector pinout		1	nc	2	RS232RX PC	3	RS232TX PC	4	NC	5	GND	6	nc	7	nc	8	nc	9	nc
DB9 connector pinout																										
1	nc																									
2	RS232RX PC																									
3	RS232TX PC																									
4	NC																									
5	GND																									
6	nc																									
7	nc																									
8	nc																									
9	nc																									
Rif. / Ref.	Q.tà / Q.ty	Materiale / Material		N. articolo / Item N.																						
Progettato da / Designed by	Contr. da / Ckd. by	Approvato da / Approved by	Nome file / File name		Data / Date	Scala / Scale																				
L.I.																										
		Titolo / Title <b>Cavo di programmazione RS232 via Analog per LCU-ONE Can+Analog</b>																								
N. disegno / Drawing N.				Rev. / Rev.		Foglio / Sheet <b>1 di 1</b>																				
<b>V02359130</b>																										

N.rev. / Rev. N.	Descrizione / Description	Data / date	Firma / Sign	Contr. da / Ckd. by										
<p><b>Analog connection cable for LCU-ONE CAN+Analog plastic Binder</b></p>  <p>4 pins Deutsch female connector</p> <p>4 pins Binder 719 male connector</p>														
		 <p>4 pins Binder 719 male connector pinout Contacts insertion view</p>		<table border="1"> <thead> <tr> <th colspan="2">Binder connector Pinout</th> </tr> </thead> <tbody> <tr> <td>1</td> <td>Lambda out</td> </tr> <tr> <td>2</td> <td>GND</td> </tr> <tr> <td>3</td> <td>nc</td> </tr> <tr> <td>4</td> <td>nc</td> </tr> </tbody> </table>	Binder connector Pinout		1	Lambda out	2	GND	3	nc	4	nc
Binder connector Pinout														
1	Lambda out													
2	GND													
3	nc													
4	nc													
		 <p>4 pins Deutsch female connector pinout Contacts insertion view</p>		<table border="1"> <thead> <tr> <th colspan="2">Deutsch connector pinout</th> </tr> </thead> <tbody> <tr> <td>1</td> <td>Lambda out</td> </tr> <tr> <td>2</td> <td>GND</td> </tr> <tr> <td>3</td> <td>nc</td> </tr> <tr> <td>4</td> <td>nc</td> </tr> </tbody> </table>	Deutsch connector pinout		1	Lambda out	2	GND	3	nc	4	nc
Deutsch connector pinout														
1	Lambda out													
2	GND													
3	nc													
4	nc													
Rif. / Ref.	Q.tà / Q.ty	Materiale / Material		N. articolo / Item N.										
Progettato da / Designed by L.I.	Contr. da / Ckd. by	Approvato da / Approved by	Nome file / File name	Data / Date Scala / Scale										
		Titolo / Title Cavo di collegamento Analog per LCU-ONE CAN+Analog Binder plastico												
		N. disegno / Drawing N. 02.359.060	Rev. / Rev.	Foglio / Sheet 1 di 1										

## Analog connection cable for LCU-ONE CAN+Analog metallic Binder

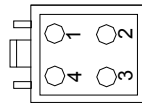

4 pins Deutsch female connector pinout  
Contacts insertion view

Deutsch connector pinout	
1	Lambda out
2	GND
3	nc
4	nc

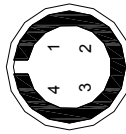

4 pins Binder 712 male connector pinout  
Contacts insertion view

Binder connector pinout	
1	Lambda out
2	GND
3	nc
4	nc

Rif. / Ref.	Q.tà / Q.ty	Materiale / Material		N. articolo / Item N.		
Progettato da / Designed by L.I.	Contr. da / Ckd. by	Approvato da / Approved by	Nome file / File name	Data / Date	Scala / Scale	
 Racing Data Power		Titolo / Title <b>Cavo di collegamento Analog per LCU-ONE CAN+Analog Binder metallico</b>				
		N. disegno / Drawing N. <b>02.359.070</b>			Rev. / Rev.	Foglio / Sheet <b>1 di 1</b>

## CAN termination cap pinout



6 pins Deutsch  
male connector

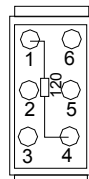





6 pins Deutsch male  
connector pinout  
Contacts insertion view

**Note:**

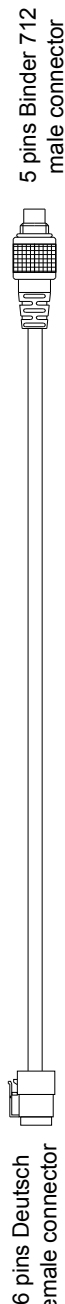
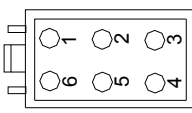
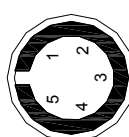
there is a 120 Ohm  
resistance between pins 1  
and 4 of the connector

Rif. / Ref.	Q.tà / Q.ty	Materiale / Material		N. articolo / Item N.		
Progettato da / Designed by L.I.	Contr. da / Ckd. by	Approvato da / Approved by	Nome file / File name	Data / Date	Scala / Scale	
 Racing Data Power		Titolo / Title Pinout tappo di terminazione linea CAN				
		N. disegno / Drawing N.	02.359.080	Rev. / Rev.	Foglio / Sheet <b>1 di 1</b>	

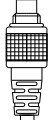
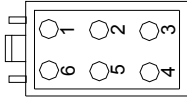
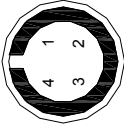
N.rev. / Rev. N.		Descrizione / Description			Data / date	Firma / Sign	Contr. da / Ckd. by																						
<p><b>CAN connection cable for LCU-ONE Can+Analog metallic Binder</b></p>  <p>6 pins Deutsch female connector</p> <p>5 pins Binder 712 male connector</p> <div style="display: flex; justify-content: space-around;"> <div style="text-align: center;">  <p>6 pins Deutsch female connector pinout Contacts insertion view</p> <table border="1"> <caption>Deutsch connector Pinout</caption> <tr><td>1</td><td>CAN+</td></tr> <tr><td>2</td><td>GND</td></tr> <tr><td>3</td><td>+VB</td></tr> <tr><td>4</td><td>CAN-</td></tr> <tr><td>5</td><td>nc</td></tr> <tr><td>6</td><td>nc</td></tr> </table> </div> <div style="text-align: center;">  <p>5 pins Binder 712 female connector Pinout Contacts insertion view</p> <table border="1"> <caption>Binder connector pinout</caption> <tr><td>1</td><td>CAN+</td></tr> <tr><td>2</td><td>GND</td></tr> <tr><td>3</td><td>+VB</td></tr> <tr><td>4</td><td>CAN-</td></tr> <tr><td>5</td><td>nc</td></tr> </table> </div> </div>								1	CAN+	2	GND	3	+VB	4	CAN-	5	nc	6	nc	1	CAN+	2	GND	3	+VB	4	CAN-	5	nc
1	CAN+																												
2	GND																												
3	+VB																												
4	CAN-																												
5	nc																												
6	nc																												
1	CAN+																												
2	GND																												
3	+VB																												
4	CAN-																												
5	nc																												
Rif. / Ref.	Q.tà / Q.ty	Materiale / Material			N. articolo / Item N.																								
Progettato da / Designed by L.I.		Contr. da / Ckd. by	Approvato da / Approved by	Nome file / File name	Data / Date	Scala / Scale																							
		Titolo / Title Cavo di collegamento CAN per LCU-ONE Can+Analog Binder metallico																											
		N. disegno / Drawing N. V02359100			Rev. / Rev.	Foglio / Sheet 1 di 1																							

N.rev. / Rev. N.	Descrizione / Description	Data / date	Firma / Sign	Contr. da / Ckd. by																								
<p style="font-size: 24px; font-weight: bold; margin: 0;">CAN connection cable for LCU-ONE Can+Analog plastic Binder</p> <div style="display: flex; justify-content: space-around; align-items: center;"> <div style="text-align: center;">  <p>6 pins Deutsch female connector</p> </div> <div style="text-align: center;">  <p>4 pins Binder 719 male connector</p> </div> </div> <div style="display: flex; justify-content: space-around; margin-top: 20px;"> <div style="text-align: center;">  <p>6 pins Deutsch female connector pinout Contacts insertion view</p> </div> <div style="text-align: center;">  <p>4 pins Binder 719 female connector pinout contacts insertion view</p> </div> </div> <div style="display: flex; justify-content: space-around; margin-top: 20px;"> <table border="1" style="border-collapse: collapse; text-align: center;"> <tr><th colspan="2">Deutsch connector pinout</th></tr> <tr><td>1</td><td>CAN+</td></tr> <tr><td>2</td><td>GND</td></tr> <tr><td>3</td><td>+VB</td></tr> <tr><td>4</td><td>CAN-</td></tr> <tr><td>5</td><td>nc</td></tr> <tr><td>6</td><td>nc</td></tr> </table> <table border="1" style="border-collapse: collapse; text-align: center;"> <tr><th colspan="2">Binder connector pinout</th></tr> <tr><td>1</td><td>CAN+</td></tr> <tr><td>2</td><td>GND</td></tr> <tr><td>3</td><td>+VB</td></tr> <tr><td>4</td><td>CAN-</td></tr> </table> </div>					Deutsch connector pinout		1	CAN+	2	GND	3	+VB	4	CAN-	5	nc	6	nc	Binder connector pinout		1	CAN+	2	GND	3	+VB	4	CAN-
Deutsch connector pinout																												
1	CAN+																											
2	GND																											
3	+VB																											
4	CAN-																											
5	nc																											
6	nc																											
Binder connector pinout																												
1	CAN+																											
2	GND																											
3	+VB																											
4	CAN-																											
Rif. / Ref.	Q.tà / Q.ty	Materiale / Material		N. articolo / Item N.																								
Progettato da / Designed by	Contr. da / Ckd. by	Approvato da / Approved by	Nome file / File name	Data / Date																								
L.I.				Scala / Scale																								
		<p>Titolo / Title <b>Cavo di collegamento CAN per LCU-ONE Can+Analog Binder plastico</b></p>																										
		N. disegno / Drawing N.	V02359110	Rev. / Rev. Foglio / Sheet <b>1 di 1</b>																								