

LCU-ONE CAN

connected to

MYCIRCON4

User Manual



Racing Data Power



INDEX

Chapter 1 – LCU–ONE Description.....	2
Chapter 2 – LCU–ONE and Lambda probe mounting.....	3
Chapter 3 – Connection to MyChron4 660.....	5
Chapter 4 – Visualization on MyChron4 660.....	6
Chapter 5 – Data Analysis with QMAn	8
Appendix – Part Numbers and technical drawings	9
“A” – Part Numbers	9
“B” – Technical drawings.....	9

Chapter 1 – LCU-ONE Description

LCU-ONE is a lambda controller unit for the wide band BOSCH LSU 4.9 Lambda probe; it fits petrol (2 and 4 strokes), diesel and methane engines as well as alcohol based fuel engines. It is intended to check lambda probe proper working as well as to transmit the Air/fuel ratio values providing **MyChron4 660** with lambda values through the CAN bus.

Lambda value is defined as:

LAMBDA = (A/F) / (A/F) Stoichiometric

Where:

A= incoming part of air;

F= parts of petrol the carburetor injects into the engine;

A / F Stoichiometric = parts of air needed to burn Stoichiometric F;

Speaking about gasoline, for example, it needs 14,57 parts of air to completely burn a part of gasoline, obtaining Lambda value=1 read by the probe.

LCU-ONE controller can detect lambda values in a range from 0.65 to 1.6 (free air).

LAMBDA value lower than 1 means a rich mixture, while LAMBDA value higher than 1 means a lean mixture.

Wide band Lambda probes need to be heated to work properly and not poisoned with exhaust gas; **LCU-ONE** controller precisely manages the probe heater so to keep temperature value within the optimum working range.

Lambda probe used with **LCU-ONE** controller becomes very hot (around 700-800 °C, 1292-1472 °F) during its working period, it is thereby necessary **AVOIDING**:

- Touching it
- Placing it in contact with flammable stuff or fuel.

Please note : disrespect of these precautions can use cause shocks, burnings or explosions.

Chapter 2 – LCU-ONE and Lambda probe mounting

LCU-ONE controller should be installed in a flat location and far from heat sources; it should be mounted steady using the suited bracket.

The wiring has to be arranged so to avoid it pressing near to heat sources.

BOSCH LSU 4.9 lambda probe should be installed on the vehicle exhaust pipe using a specific adaptor that comes with the kit and should be welded on the same pipe. The probe should be sufficiently near to the engine.

Probe working temperature should not exceed 900°C (1652°F), neither be exposed to the free flame coming from the exhaust system.

Probe installation angle should be at least of 10° to avoid liquid condensation stuff to come in contact with the probe, polluting it.

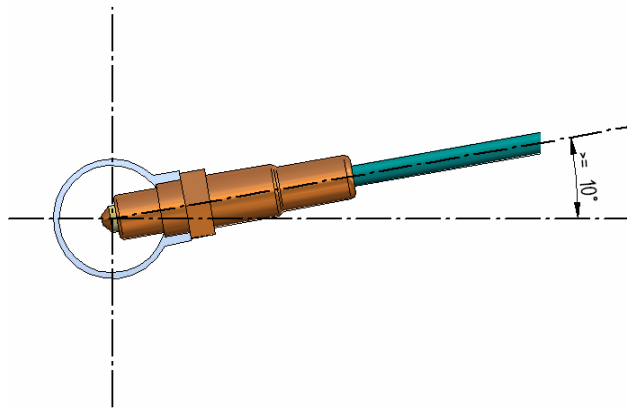

Once installed the probe, please pay attention not to let the cable pass near to excessive heat sources (the exhaust pipe for example).

BOSCH LSU 4.9 probe auto-calibrates: no calibration is then required by the user.

Solvents or additives should not be used to clean the probe connector. To protect the probe we would suggest removing it from the jr. dragster when cleaning the vehicle to avoid polluting the probe with detergents.

REMINDER: never switch the vehicle on with Lambda probe installed and not connected to a correctly working **LCU-ONE** controller: a probe not heated and exposed to exhaust gas would be irretrievably damaged.

Warning: BOSCH LSU 4.9 Lambda probe has been designed to be used with unleaded or diesel engine; it can be used with other kinds of engine too but its duration needs to be verified by the user with specific tests.

We would suggest installing Lambda controller and the related probe as shown in the following pictures.

Moreover we advise to install a 10 Ampere fuse in series between the external battery and lambda controller.

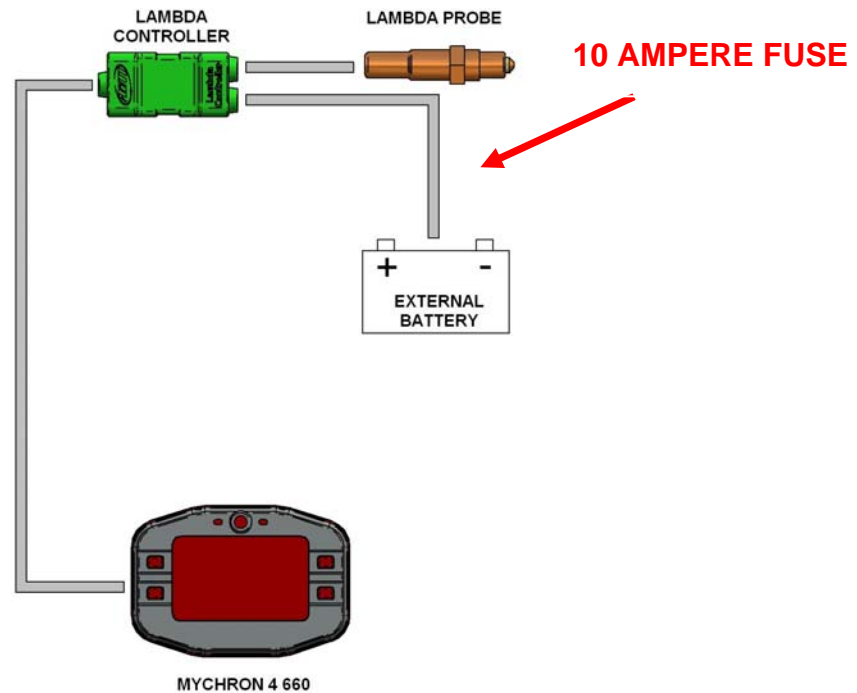

We would suggest installing the probe in the exhaust pipe (see picture below):



Chapter 3 – Connection to MyChron4 660

Connecting Lambda controller to MyChron4 660, the system automatically recognises the peripheral at start up.

In case the only available peripheral is **LCU-ONE CAN**, it can be connected directly to MyChron4 660 through the back connector labelled as EXP/PC.

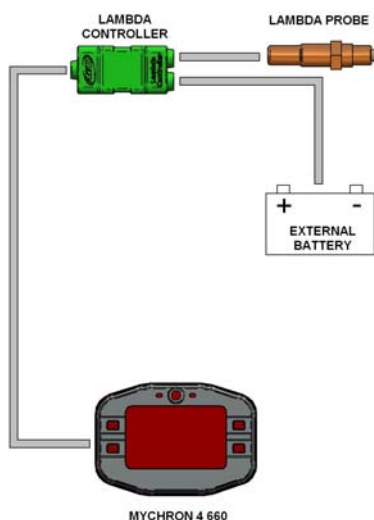

In the following picture, **LCU-ONE CAN** is connected to MyChron4 660 through Data Hub, the CAN connections multiplier.

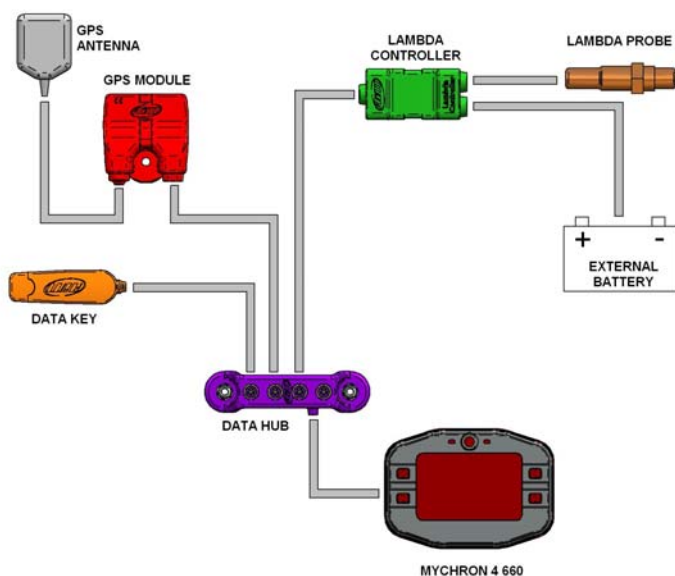

Though the system is powered through Lambda controller connected to the battery, it is suggested to leave MyChron4 660 internal batteries in the logger. Lambda controller switches automatically off when MyChron4 660 is switched off.

Chapter 4 – Visualization on MyChron4 660

In order to visualize the values of lambda on your Mycron4 660, turn the engine on and press “>>/OFF” button on your gauge keyboard.

The values will be visualized with RPM value exceeding 500.

3 values will appear on the screen and remain visualized for ten seconds:

RPM Value, **EGT Value** and **Lambda Value**.

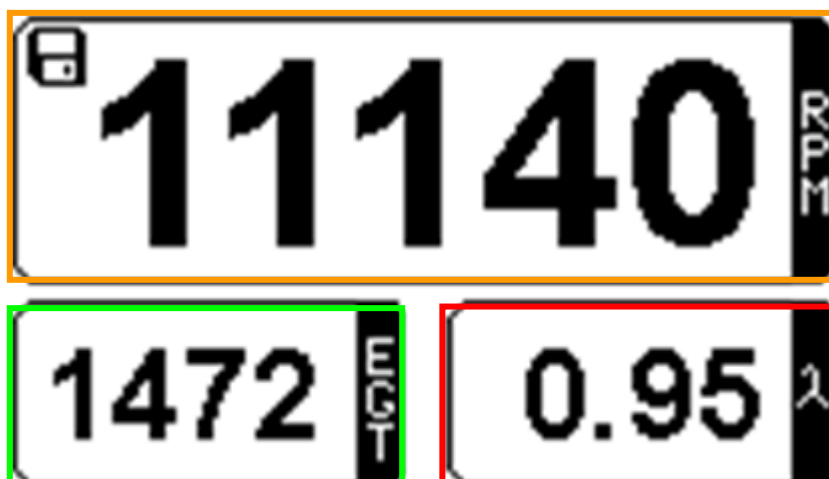

After this time the original values will appear again: **RPM Value**, **EGT Value** and **CHT Value**.

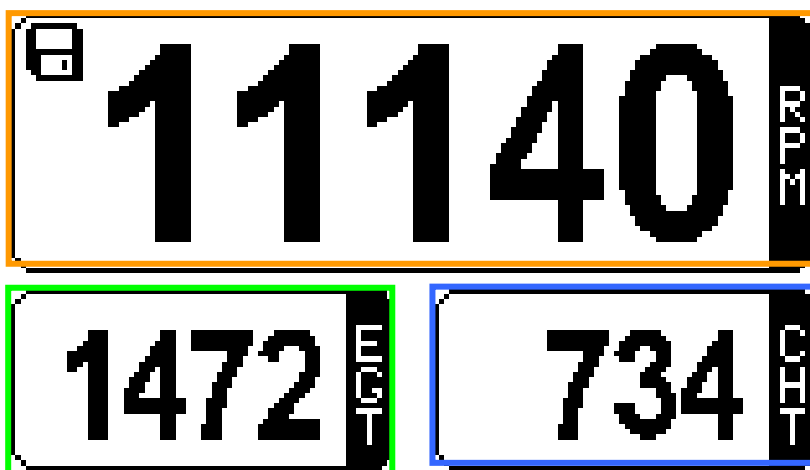

Pressing "ON/VIEW" button Lambda controller page is shown:

```
Lambda Data  
  
Lambda: 0.95 LAMBDA VALUE  
  
Temp: 1356°F LAMBDA  
TEMPERATURE  
  
Diagn: Sensor OK DIAGNOSIS
```

This page shows Lambda value, Lambda temperature and diagnosis.

Diagnosis status can be :

Sensor Ok: probe status is OK

Sensor Open: the probe is not connected to the controller and the circuit is open

Sensor Fault: short circuit on the wiring

Chapter 5 – Data Analysis with QMAN

During data analysis, the presence of Lambda controller adds two channels to measures and laps toolbar (as shown in the picture below):

Lambda: shows lambda value reordered during the session;

Lambda _Temp: indicates the probe internal temperature while working

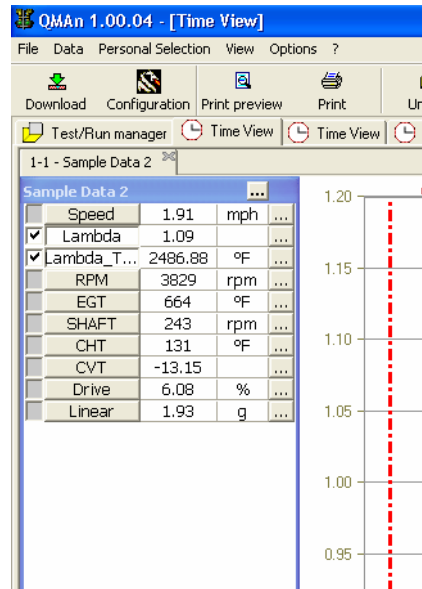

To better analyse carburetor values we would suggest you to show XY diagram of Lambda probe with RPM values on abscissa axle and Lambda values on ordinate axle on the graph.

In this way a more immediate reading of carburetion status will be available.

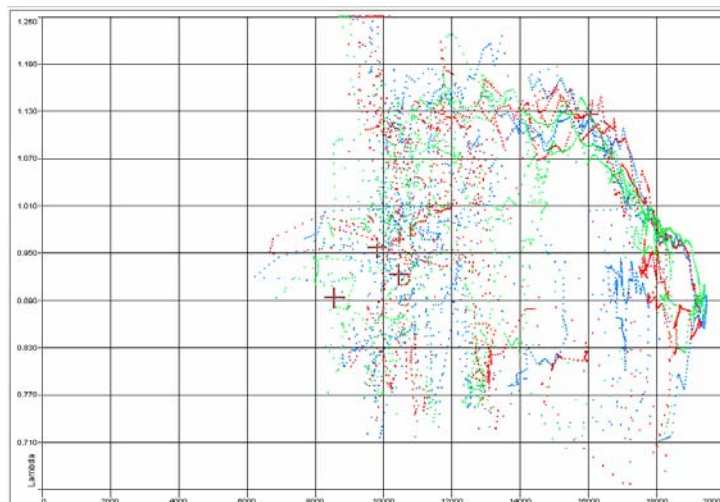

Appendix – Part Numbers and technical drawings

“A” – Part Numbers

Controller LCU-ONE (Complete kit with Lambda probe)	X08LCU03K0
BOSH LSU 4.9 Lambda probe	X05LSU490

“B” – Technical drawings

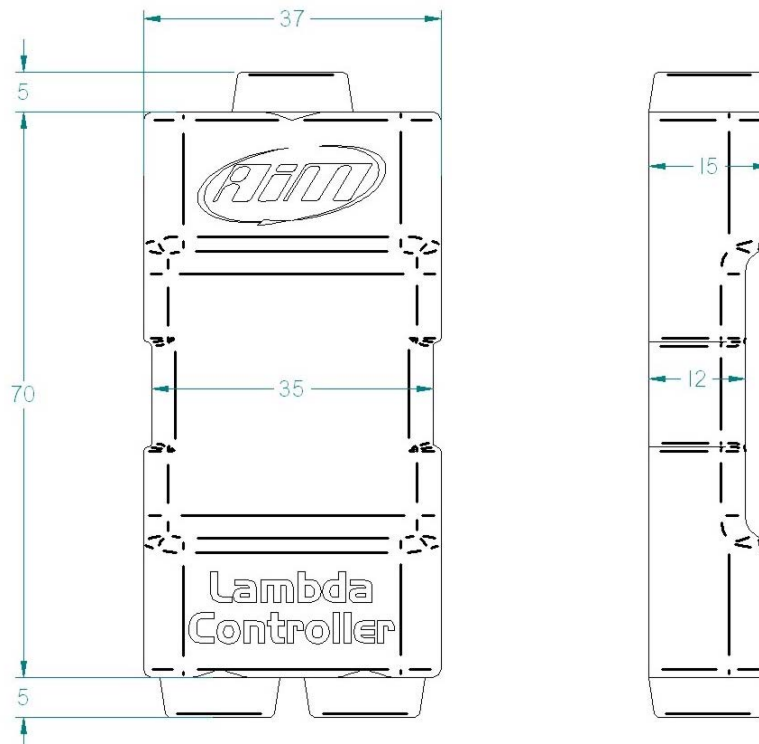
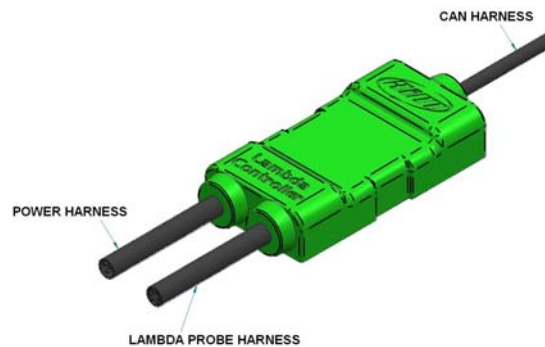

LCU-ONE CAN pinout

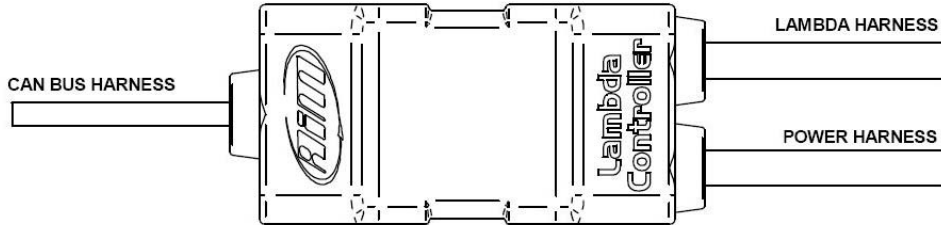

CAN BUS HARNESS	
1	CAN+
2	GND
3	+Vb
4	CAN-
5	Vbext

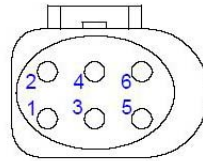

LAMBDA HARNESS	
1	IP+
2	IP-/VS
3	H-
4	H+
5	Rcal
6	VS+

POWER HARNESS	
red	V battery
black	GND
black	GND